

PARTNER

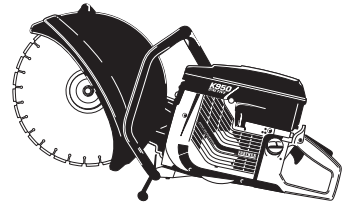

IPL, K 650 Active II, K 700 Active II, 2001-06, 106 27 55-61

*K 650 Active II
K 700 Active II*

Reservdelar

Spare parts

Ersatzteile

Pieces de rechange

Piezas de repuesto

Ricambi

*Peças
sobresselente*

106 27 55-61

PARTNER®

No.	Pos.	Description	No.	Pos.	Description
501 22 02-01	L	Plug	503 25 00-01	K	Ball bearing MFG SKF
501 22 03-01	L	Plug	503 25 21-01	A	Ball bear. 6202 DDU/C3
501 22 04-01	L	Ball	503 26 02-04	K	Sealing ring
501 22 05-01	L	Spring	503 26 30-21	M	O-ring
501 22 08-01	L	Gasket	503 28 90-17	J	Piston ring
501 22 09-01	L	Diaphragm	503 40 13-02	C	Bracket left
501 22 12-01	L	Fuel pump diaphragm	503 40 17-01	C	Contact spring
501 22 13-01	L	Gasket, pump side	503 40 27-01	K	Spacer
501 22 14-01	L	Cap	503 41 18-02	F	Cable
501 22 15-01	L	Screw	503 44 31-01	K	Gasket
501 22 17-01	L	Spring	503 49 10-01	J	Gasket
501 22 20-01	L	Lever	503 53 40-01	L	Nipple
501 22 21-01	L	Shaft	503 55 22-01	J	Plug
501 22 24-01	L	Filter	503 57 86-01	L	Ball
501 22 25-01	L	Spring	503 57 87-01	L	Screw
501 26 85-01	L	Idle adj. screw	503 57 89-01	K	Holder
501 26 89-01	L	Needle H	503 65 27-01	L	Screw
501 42 71-01	L	Bushing	503 65 30-01	L	Washer
501 48 50-01	L	Gasket	503 65 31-01	L	Washer
501 48 52-01	L	Screw	503 71 53-01	J	Valve decompr.
501 48 54-02	F	Spark plug conn. kit	503 77 98-01	L	Valve
501 49 48-02	L	Diaphragm/gasket set	503 84 50-01	F	Cable
501 63 48-01	F	Spring	503 90 17-01	F	Ignition module
501 67 32-03	F	Pawl	504 35 72-01	K	Fuel filter
501 69 17-02	H	Comb. tool	505 26 76-73	B	Spacer
501 76 83-04	K	Hose	505 26 83-03	B	Cover
501 76 83-26	K	Hose, 245 mm	505 26 94-27	B	Throttle rod
501 81 99-01	F	Screw M5x14	505 27 75-16	F	Insulating cap
501 82 18-01	L	Retaining ring	505 27 90-60	G	Insul. flange
503 12 79-02	E	Starter handle	505 27 91-03	B	Throttle control
503 15 59-02	C	Bracket right	505 27 91-04	B	Throttle catch
503 15 80-01	K	Crankshaft	505 27 95-11	C	Absorber
503 20 00-01	BC	Screw M6SF 5x20	505 27 95-13	C	Absorber
503 20 00-03	AD	Screw M6SF 5x12	505 29 56-14	B	Spring
503 20 00-04	AC	Screw M6SF 5x16	505 30 23-33	K	Needle bearing
503 20 00-05	CJ	Screw M6SF 5x25	505 30 24-15	B	Needle bearing
503 20 00-07	CK	Screw M6SF 5x40	505 30 32-37	B	Clutch
503 20 00-08	BCK	Screw M6SF 5x30	505 30 32-47	B	Centrif. weight
503 20 00-09	J	Screw M6SF 5x45	505 31 61-14	L	Shutter
503 20 00-10	C	Screw M6SF 5x55	505 31 64-58	L	Pressure spring
503 20 00-12	B	Screw M6SF 5x70	505 31 64-95	L	Sealing ring
503 20 00-35	C	Screw	505 31 65-50	L	Needle
503 20 00-45	A	Screw	505 31 66-05	L	Spring
503 20 02-90	D	Screw	505 31 66-19	L	Throttle shaft
503 20 21-75	G	Screw	505 34 07-54	B	Handle, left half
503 20 25-20	F	Screw	505 34 07-95	B	Handle, right
503 20 30-09	A	Screw	505 34 11-62	J	Piston cpl 50 mm
503 20 34-19	E	Screw	505 35 01-50	J	Silencer
503 20 34-25	E	Screw	505 39 75-13	A	Information label
503 20 34-42	D	Screw	505 39 75-88	B	Decal
503 21 06-19	M	Screw	506 02 84-01	A	Washer
503 21 06-32	C	Screw	506 02 85-64	A	Shaft
503 21 07-22	E	Screw	506 02 86-01	A	Spacer
503 21 28-10	CE	Screw	506 02 87-01	A	Washer
503 22 00-01	AB	Nut M6MF M5	506 02 88-30	A	Bushing
503 22 04-01	F	Lock nut	506 02 91-02	A	Bearing housing
503 22 65-04	C	Nut	506 02 92-01	A	Guard
503 22 66-01	A	Nut	506 02 95-01	A	Hose
503 23 00-05	A	Washer 6.5x11	506 02 95-03	A	Hose
503 23 00-11	B	Washer 5.3x12	506 02 96-01	A	Spring
503 23 00-35	C	Washer	506 02 98-01	A	Control knob
503 23 00-42	FG	Washer	506 02 98-04	A	Control knob
503 23 01-04	A	Washer 15x21	506 03 00-01	A	Pulley
503 23 01-11	B	Washer	506 03 06-02	A	Adjuster
503 23 04-01	B	Washer	506 03 32-02	AK	Screw
503 23 51-08	F	Spark plug RCJ7Y	506 03 45-01	A	Washer

No.	Pos.	Description	No.	Pos.	Description
506 03 62-01	A	Spacer	506 26 41-01	K	Fuelfilter
506 03 62-02	A	Spacer	506 26 41-11	K	Fuel filter cpl
506 03 62-04	A	Spacer	506 26 75-01	A	Washer
506 03 88-01	A	Warning label	506 26 85-01	G	Rubber seal
506 03 95-20	A	Bushing	506 27 11-01	K	Fuel filter weight
506 03 95-22	A	Bushing	506 27 14-01	L	Screw
506 03 95-25	A	Bushing	506 27 56-01	L	Choke shaft
506 03 99-01	C	Support	506 27 57-01	L	Felt seal
506 07 07-01	A	Flange, support	506 27 61-01	L	Cup
506 07 11-13	K	Hose	506 27 67-41	A	Belt
506 07 25-01	B	Cutting arm	506 27 84-12	D	Decal
506 07 26-04	C	Handle	506 27 84-21	D	Decal
506 07 37-01	B	Drive wheel	506 27 84-23	D	Decal
506 07 66-03	K	Crankcase cpl	506 28 39-30	D	Sealing
506 09 56-02	M	Clamp	506 29 21-01	K	Gasket
506 09 64-01	G	Gasket	506 29 56-01	M	Nipple
506 09 82-01	B	Spring	506 29 57-01	M	Nipple
506 09 90-01	J	Piston cpl 50 mm	506 29 65-01	C	Absorber
506 09 92-12	J	Cylinder cpl	506 29 88-01	M	Screw
506 13 82-01	A	Guard	506 31 15-01	L	Insert
506 13 95-11	A	Washer	506 31 15-02	L	Insert
506 13 96-01	A	Screw	506 31 61-01	L	Cover
506 14 32-01	A	Catch	506 31 74-01	K	Bushing
506 14 42-01	C	Support	506 31 77-11	M	Valve cpl
506 14 43-01	C	Support	506 31 88-01	G	Intake pipe
506 14 90-01	C	Protection	506 31 88-02	G	Intake pipe
506 21 21-01	A	Washer	506 32 02-01	G	Gasket
506 21 27-02	J	Gasket	506 32 03-01	G	Gasket
506 21 77-14	D	Cylinder cover	506 32 12-01	L	Repair kit
506 21 78-12	D	Filter holder	506 32 15-01	GL	Carburetor cpl
506 21 79-01	D	Filter cover	506 32 87-01	M	Y-tube
506 21 86-02	F	Flywheel compl.	506 32 89-03	M	Wet cutting kit
506 21 89-02	E	Starter housing	506 32 99-01	GL	Carburetor cpl
506 21 90-01	E	Air conductor	506 33 56-15	E	Starter rope
506 21 91-01	K	Grommet	506 34 07-01	J	Deflector
506 21 95-01	A	Spring	506 34 46-03	M	Handle
506 21 98-01	D	Air jet	506 34 66-01	L	Governor
506 22 23-01	D	Sealing	720 13 07-10	K	Pin
506 22 24-01	D	Sealing	721 42 58-20	C	Spring pin 4x24
506 22 42-01	D	Air filter	725 52 95-55	D	Screw MC6S 4x20
506 22 44-01	C	Guide	732 21 14-01	C	Locknut
506 22 45-01	C	Choke control	735 31 09-20	A	E-ring 5
506 22 48-01	C	Holder	735 58 18-00	B	Lock washer 2.4
506 22 63-01	D	Filter	735 88 06-00	K	Woodruff key
506 22 88-03	G	Guide	737 43 12-00	J	Retaining ring
506 23 52-02	H	Gasket set	740 42 01-00	G	O-ring
506 23 53-04	D	Decal	740 43 13-00	E	O-ring
506 23 53-05	D	Decal			
506 23 54-02	E	Decal			
506 23 61-01	K	Tank vent.			
506 23 83-01	L	Choke flap			
506 23 93-01	D	Decal			
506 24 37-13	J	Cylinder cpl			
506 25 14-01	E	Washer			
506 25 30-01	E	Spring			
506 25 59-32	K	Tank cap			
506 25 61-01	K	Tank unit			
506 25 81-02	E	Starter pulley			
506 25 82-01	D	Guard			
506 25 89-01	E	Return spring			
506 25 95-01	E	Starter device			
506 26 00-02	A	Guard			
506 26 28-01	C	Spring			
506 26 29-01	K	Protector			
506 26 30-01	C	Knob			
506 26 31-01	E	Sleeve			

A

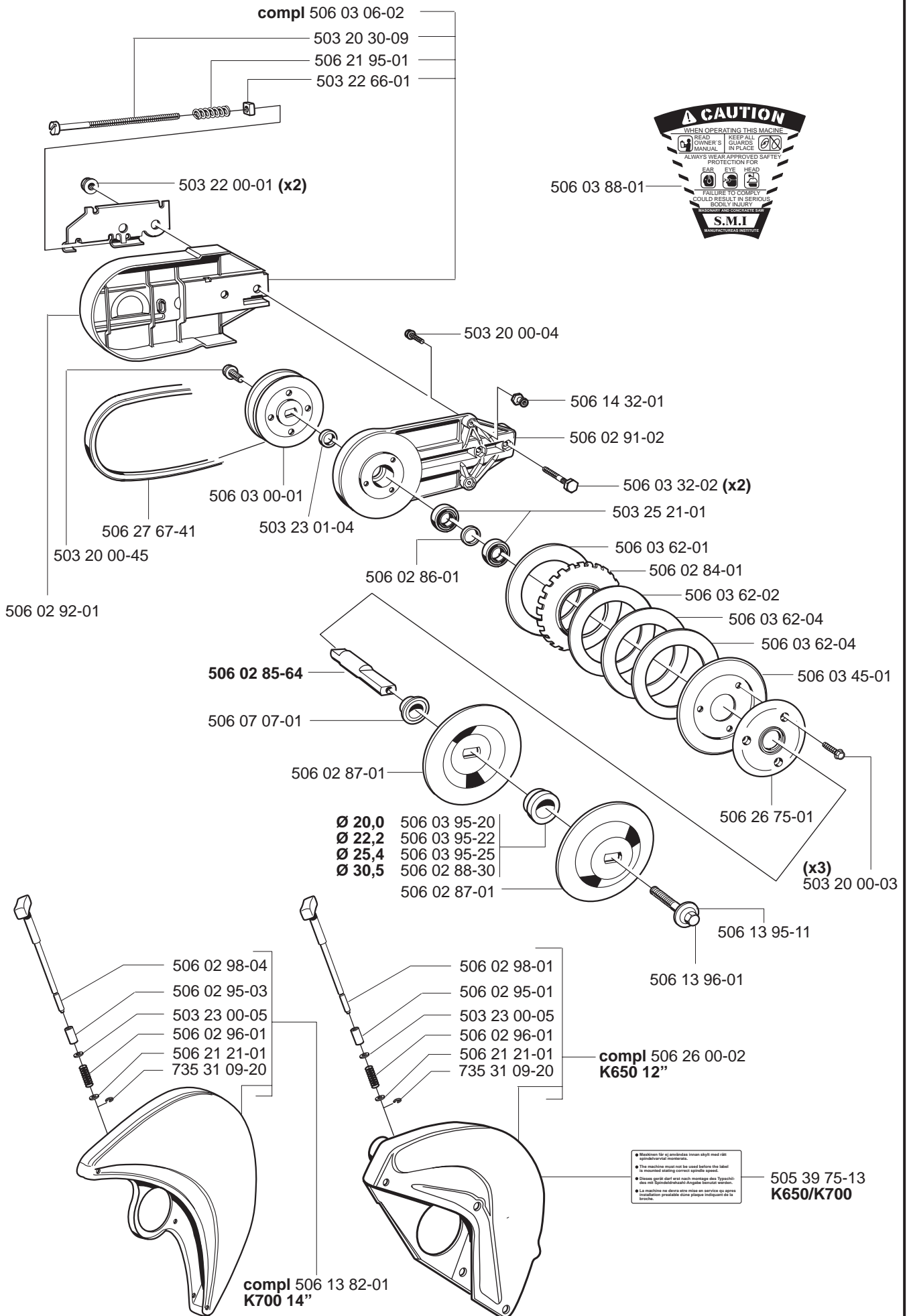

B

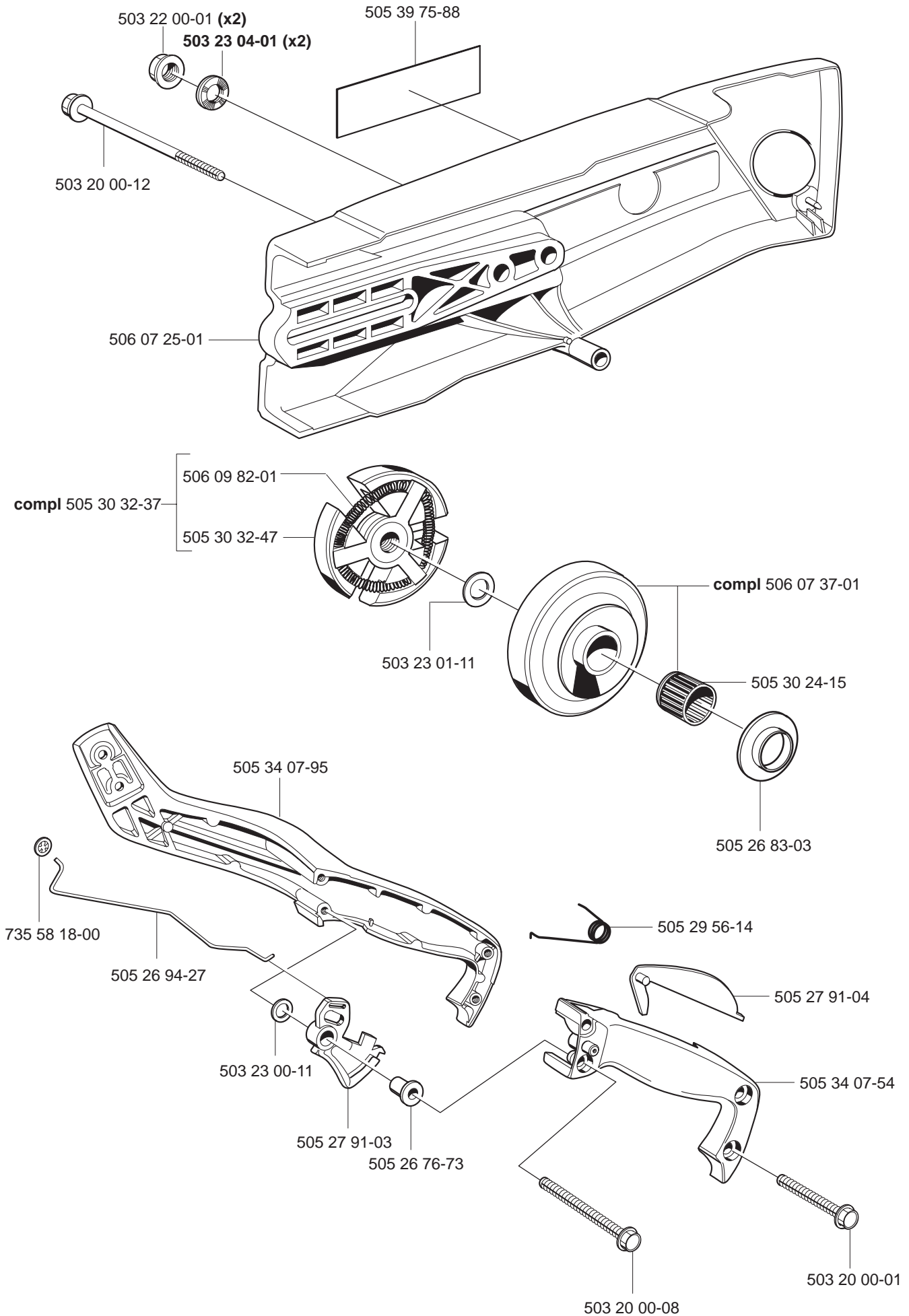

C

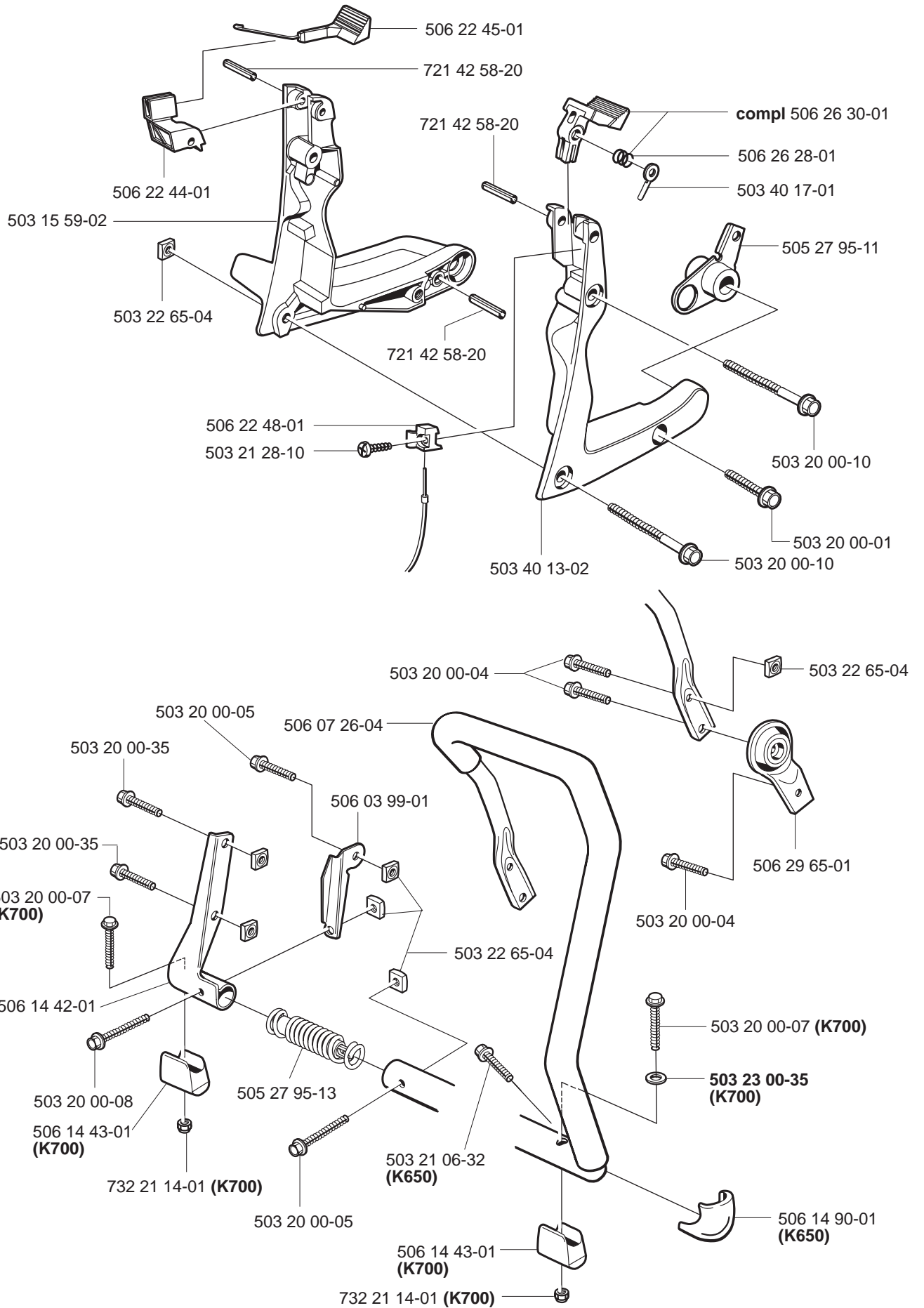

D

506 27 84-12
CE



506 27 84-23
EPA Canada



506 27 84-21
EPA USA



503 20 34-42

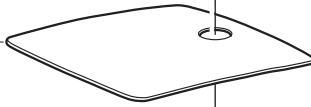

506 21 79-01

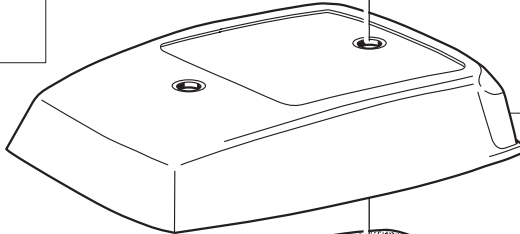

506 22 63-01

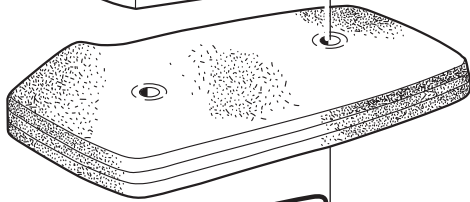

**506 25 82-01

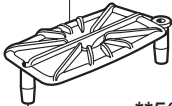

**506 28 39-30



**compl 506 21 78-12

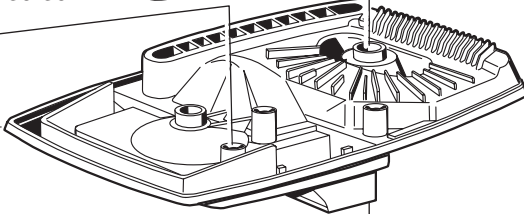

506 22 42-01

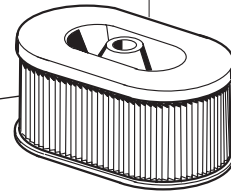

503 20 02-90



506 28 39-30*



506 23 93-01*



*compl 506 21 77-14

506 22 23-01



506 23 53-04



506 23 53-05

506 22 24-01



506 21 98-01

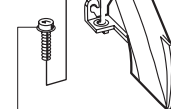

725 52 95-55

503 20 00-03

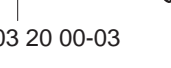

E *compl 506 25 95-01

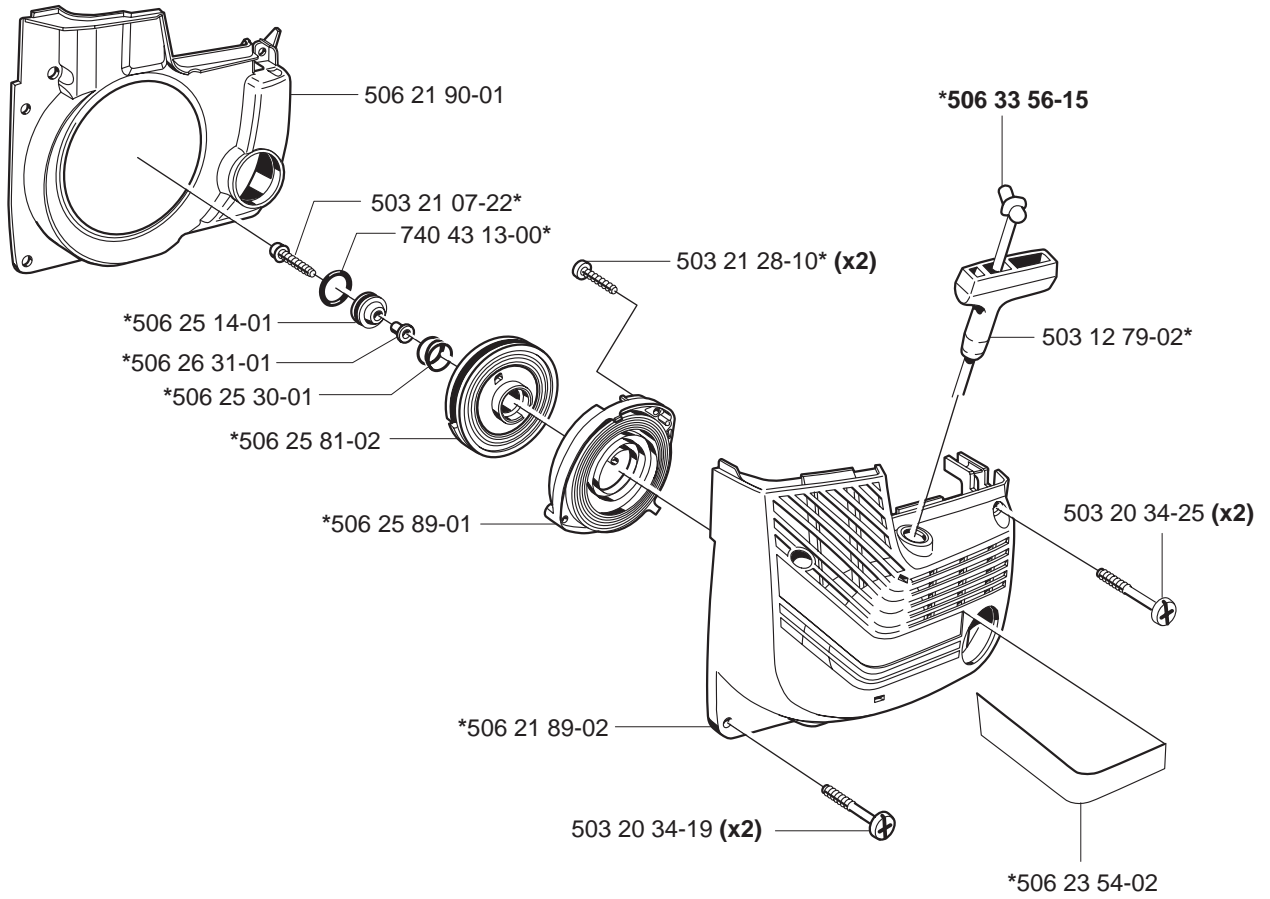

F

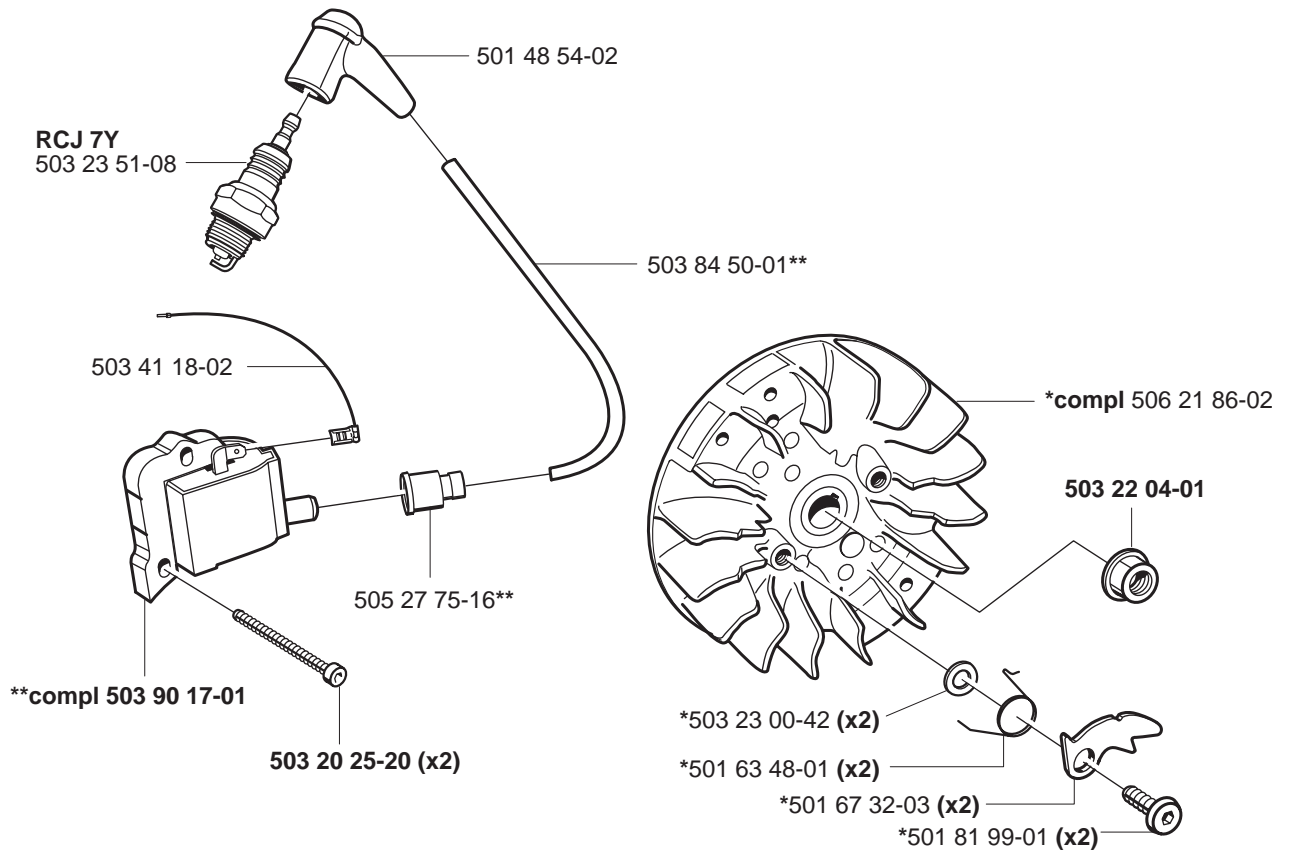

G

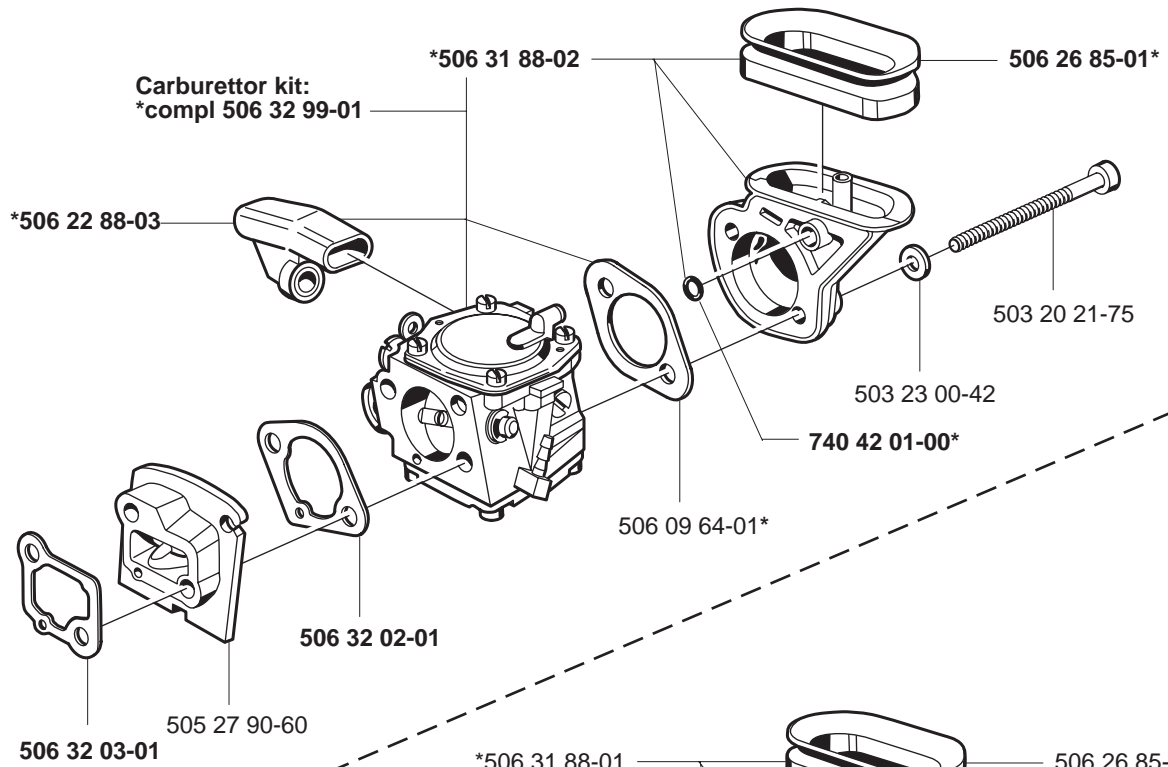

EPA

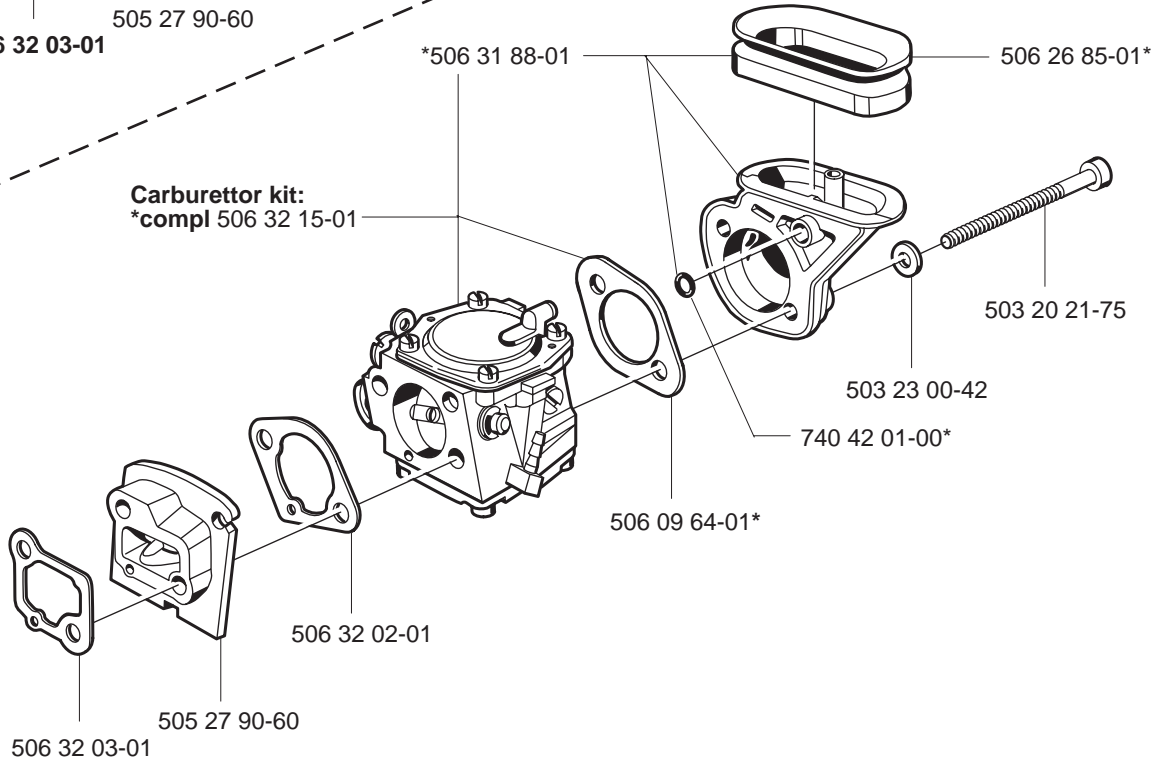

H



506 23 52-02

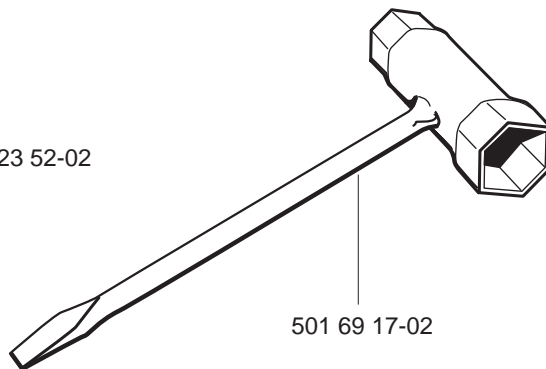

J

*compl 506 09 92-12
*compl 506 24 37-13 (EPA)

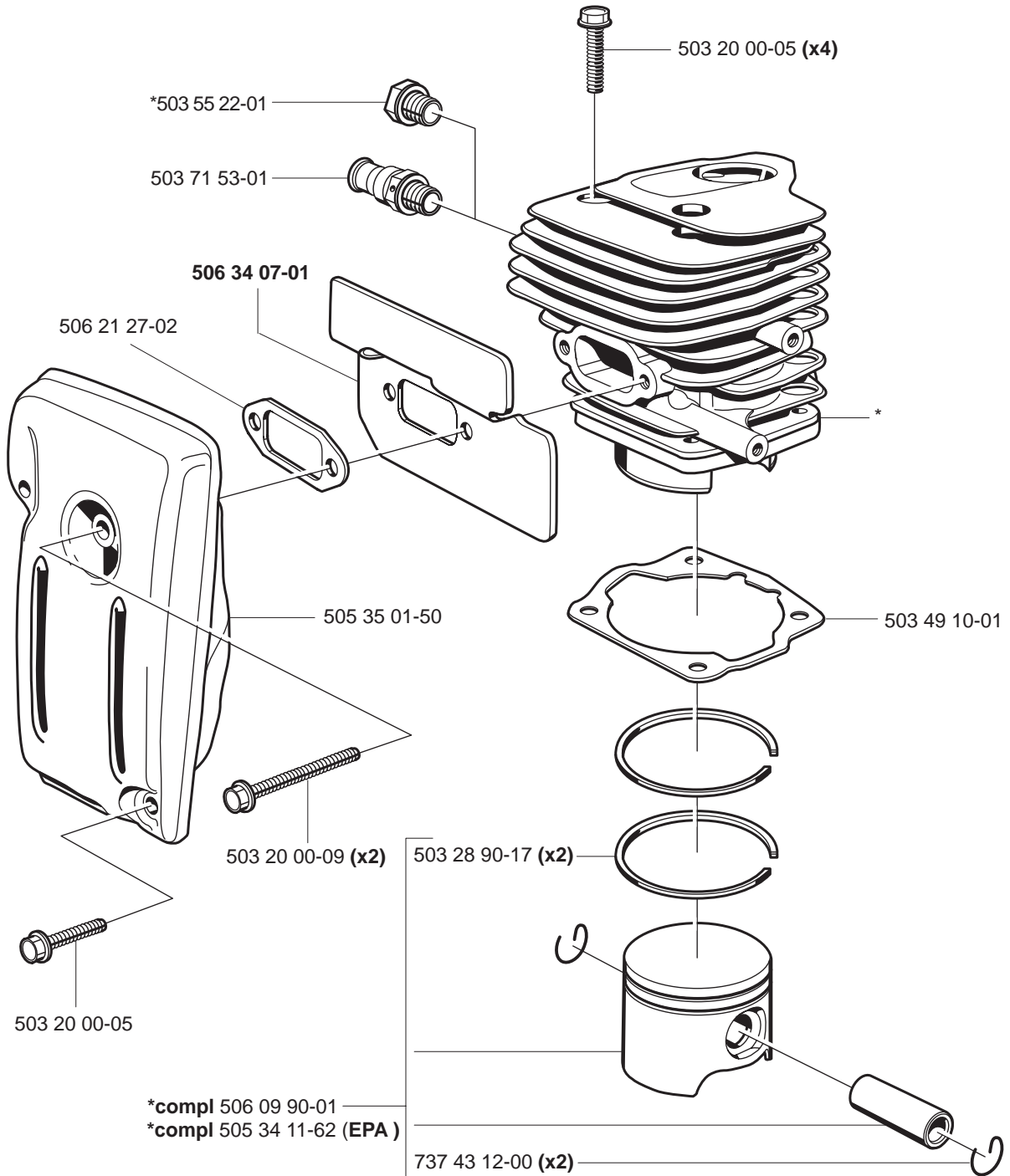

K *crankcase compl 506 07 66-03

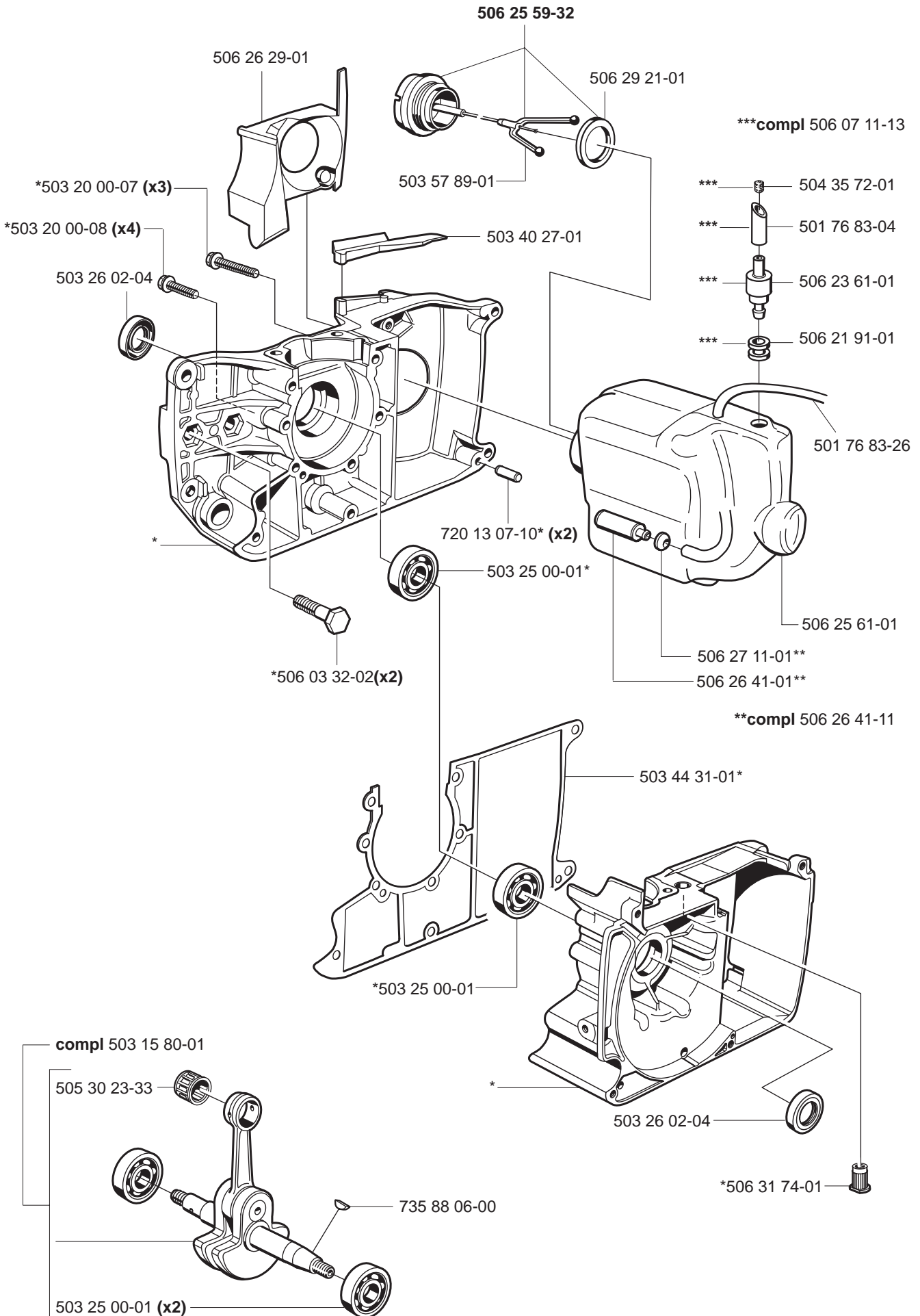

L compl 506 32 99-01 Tillotson HS 175M
 compl 506 32 15-01 Tillotson HS 175K (EPA)

Tillotson HS 175M Tillotson HS 175K

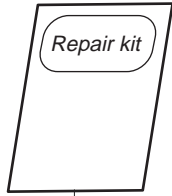

506 32 12-01

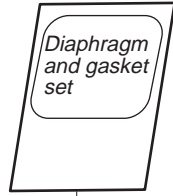

*compl 501 49 48-02

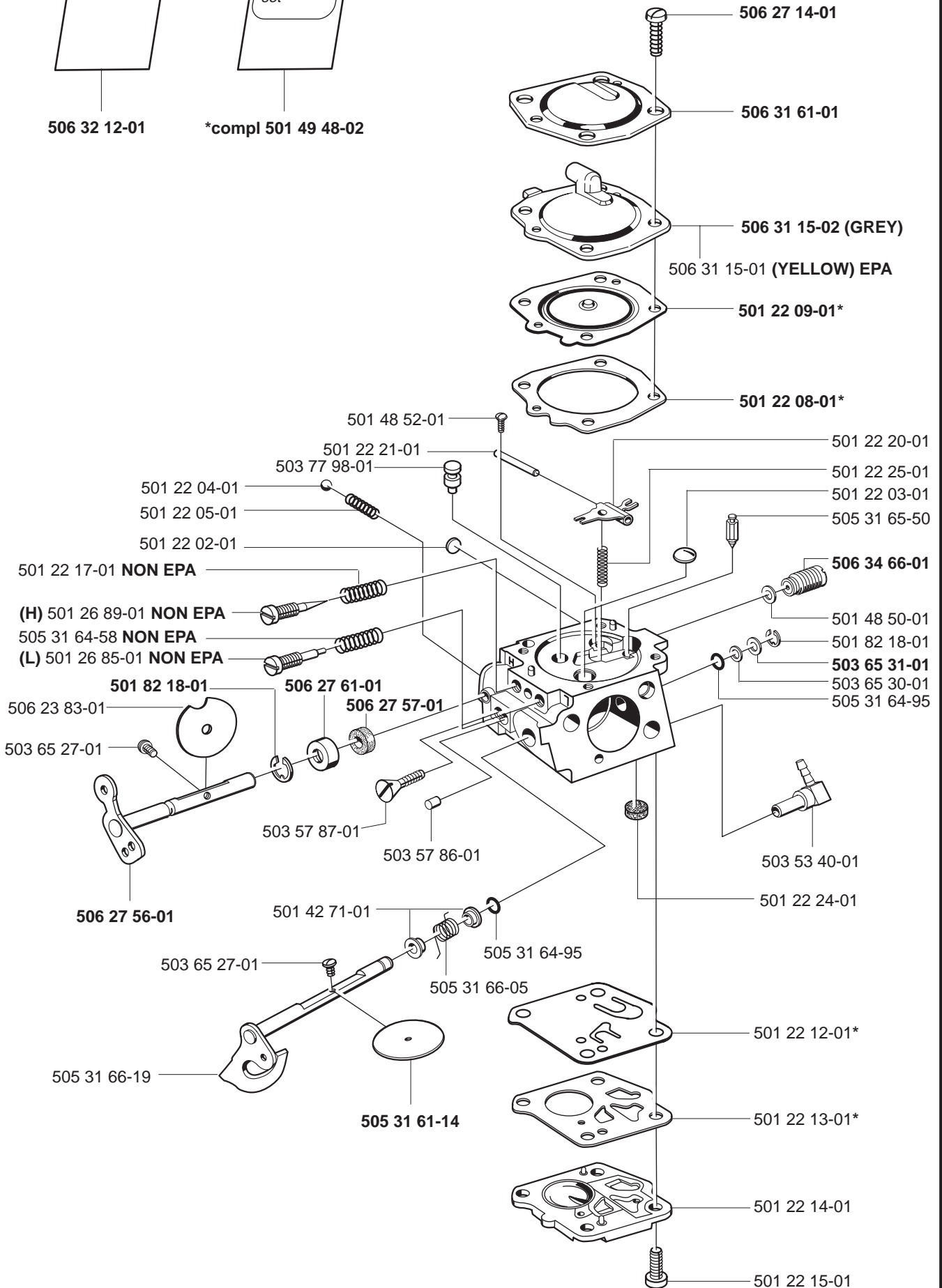

M

Wet cutting kit 506 32 89-03

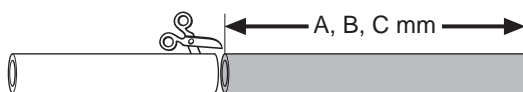
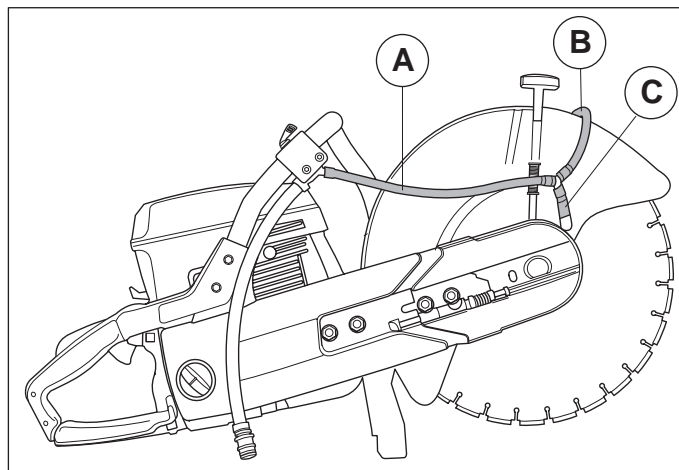
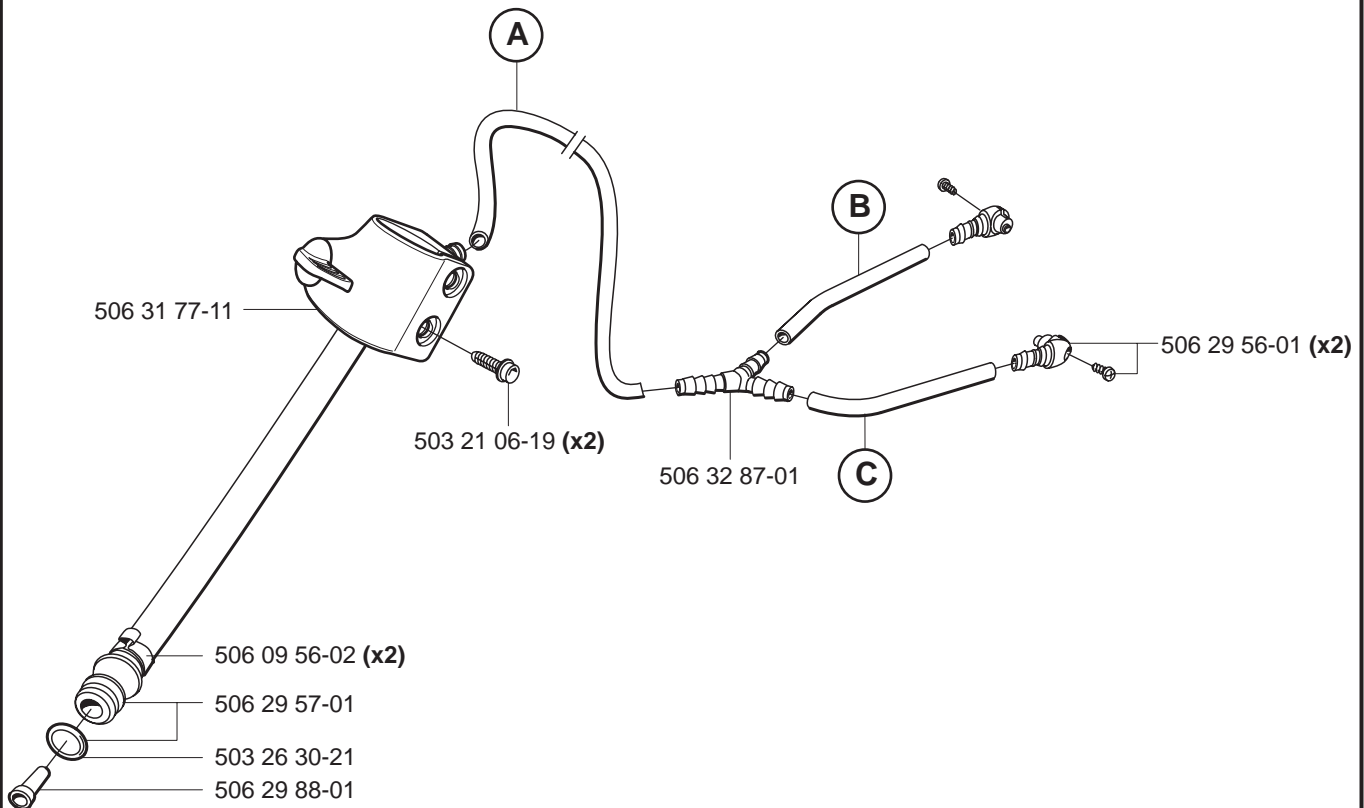

Product		A (mm)	B (mm)	C (mm)
K650A-II	12"	270	210	45
K700A-II	14"	270	300	45