

# ***PARTNER***

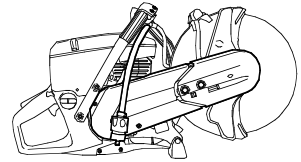

**IPL, K750, 2005-04, 544 00 18-02**

***K750***

***Reservdelar***

***Spare parts***

***Ersatzteile***

***Pieces de rechange***

***Piezas de repuesto***

***Ricambi***

***Peças  
sobresselente***

**544 00 18-02**

---

# **PARTNER®**

No.	Pos.	Description	No.	Pos.	Description
501 27 08-01	C	SLEEVE	506 02 87-01	B	WASHER
501 27 13-02	F	GROMMET	506 02 88-30	B	BUSHING
501 48 54-02	J	SPARK PLUG CONN. KIT	506 03 88-01	B	WARNING LABLE
501 63 48-01	J	SPRING	506 07 08-01	A	SPACER
501 67 32-03	J	PAWL	506 07 09-01	B	WASHER
501 76 83-28	F	HOSE	506 09 56-02	N	CLAMP
501 81 99-01	J	SCREW	506 09 58-24	N	HOSE
503 12 79-02	H	STARTER HANDLE	506 09 75-02	N	HOSE
503 16 40-01	F	VALVE	506 13 95-11	A	WASHER
503 20 00-45	A	SCREW	506 13 96-01	A	SCREW
503 20 03-12	C	SCREW	506 14 32-01	A	CATCH
503 20 72-75	A	SCREW	506 22 28-01	F	THROTTLE LOCK
503 21 07-22	H	SCREW	506 25 14-01	H	WASHER
503 21 28-06	F	SCREW	506 25 30-01	H	SPRING
503 21 28-10	HJ	SCREW	506 25 59-32	F	TANK CAP
503 21 45-16	F	SCREW	506 25 81-02	H	STARTER PULLEY
503 21 53-10	ADGL	SCREW	506 25 89-01	H	RETURN SPRING
503 21 53-20	JL	SCREW	506 26 31-01	H	SLEEVE
503 21 53-21	CGHK	SCREW	506 26 41-01	F	FILTER
503 21 53-25	D	SCREW	506 26 41-11	F	FILTER CPL
503 21 53-40	DG	SCREW	506 26 63-02	B	LONING
503 21 53-41	C	SCREW	506 26 64-01	B	FLANGE
503 21 53-56	DK	SCREW	506 26 65-01	B	FLANGE
503 21 53-56	L	SCREW	506 26 66-04	A	TENSIONER
503 21 54-20	FGN	SCREW	506 26 68-01	A	SPRING
503 22 10-11	J	NUT	506 27 11-01	F	PENDULUM
503 22 65-04	CFL	NUT	506 27 27-10	J	FLYWHEEL
503 22 66-01	A	NUT	506 27 84-32	K	DECAL
503 23 00-42	J	WASHER	506 27 84-51	K	DECAL
503 23 00-73	C	WASHER	506 27 84-53	K	DECAL
503 23 01-01	J	WASHER	506 28 40-02	B	LABEL
503 23 01-04	A	WASHER	506 28 40-04	B	LABEL
503 23 01-16	A	WASHER	506 28 40-12	B	LABEL
503 23 04-02	D	WASHER	506 28 40-14	B	LABEL
503 23 51-09	J	SPARK PLUG RCJ6Y	506 28 44-01	A	BOLT
503 25 21-01	A	BALL BEARING	506 28 73-01	A	NUT
503 25 56-01	DE	NEEDLE BEARING	506 28 84-01	A	FLANGE
503 26 02-04	C	SEALING RING	506 29 21-01	F	GASKET
503 26 30-21	N	O-RING	506 29 56-01	N	NIPPLE
503 28 32-09	LM	CARBURETOR	506 29 57-01	N	NIPPLE
503 28 90-47	D	PISTON RING	506 29 57-02	N	NIPPLE
503 40 06-06	L	HOSE	506 29 67-02	A	BELT
503 47 96-01	M	SCREW	506 29 83-63	A	SHAFT
503 48 00-01	M	PIN FULCRUM	506 29 88-01	N	SCREEN
503 48 11-01	M	PLUG	506 31 86-01	F	STOP SWITCH
503 48 18-01	M	SCREW	506 32 48-01	B	FLANGE
503 53 56-01	M	PLUG	506 32 87-01	N	TUBE
503 53 57-01	M	STRAINER	506 33 56-15	H	STARTER ROPE
503 55 22-01	D	PLUG	506 34 05-12	B	PROTECTOR
503 57 76-03	F	HOSE	506 34 05-14	B	PROTECTOR
503 57 89-01	F	HOLDER	506 34 46-01	B	HANDLE
503 61 66-01	M	GASKET	506 36 42-01	D	MUFFLER
503 66 56-01	D	VALVE	506 36 68-01	K	COVER
503 66 59-01	M	LEVER	506 36 69-01	K	BASE
503 74 43-01	C	SPRING	506 36 71-01	K	FILTER
503 74 44-04	C	CLUTCH	506 36 72-01	L	AIR FILTER
503 84 61-01	C	BUFFER	506 36 88-01	D	BRACKET
504 35 72-01	F	FUEL FILTER	506 36 91-01	C	PROTECTOR
505 27 75-16	J	INSULATING CAP	506 36 92-01	H	COVER
505 30 24-15	C	SUPPORT BUSHING	506 36 93-01	H	AIR CONDUCTOR

No.	Pos.	Description	No.	Pos.	Description
506 36 96-01	A	PULLEY	506 39 54-01	M	COLLAR
506 36 97-01	L	PIPE	506 39 55-01	M	COVER COMPENSATOR
506 36 98-01	L	PIPE	506 39 56-01	M	COVER METERING
506 37 03-01	K	JET	506 39 57-01	M	DIAPHRAGM ASSY MET.
506 37 04-01	K	BELLOW	506 39 58-01	M	GASKET
506 37 05-01	L	FLANGE	506 39 60-01	M	DIAPHRAGM PUMP
506 37 06-01	L	FLANGE	506 39 61-01	M	NOZZLE ASSY
506 37 10-71	E	FLANGE	506 39 62-01	M	GASKET, METERING
506 37 11-01	G	HANDLE	506 39 63-01	M	PUMP, COVER ASSY
506 37 13-01	F	THROTTLE ROD	506 39 64-01	M	QUAD RING
506 37 14-01	F	CHOKE CONTROL	506 39 65-01	M	SHAFT, LINKAGE
506 37 19-01	F	PLATE	506 39 66-01	M	SCREW
506 37 20-01	F	THROTTLE TRIGGER	506 39 69-01	M	SCREW
506 37 24-01	D	PISTON CPL	506 39 70-01	M	SCREW
506 37 55-01	G	SUPPORT	506 39 71-01	M	SHAFT, ASSY
506 37 56-01	G	SUPPORT	506 39 72-01	M	SCREW, THROTTLE ADJ.
506 37 57-02	C	CRANCASE	506 39 73-01	M	CHOKE SHAFT
506 37 58-02	D	DEFLECTOR	506 39 74-01	M	CHOKE SHAFT
506 37 67-01	CD	GASKET	506 39 75-01	M	SPRING
506 37 68-01	L	GASKET	506 39 76-01	M	SPRING
506 37 69-01	D	GASKET	506 39 77-01	M	SPRING
506 37 70-02	C	GASKET	506 39 78-01	M	VALVE
506 37 72-01	G	BRACKET	506 39 79-01	M	WASHER
506 37 80-01	F	GROMMET	506 39 84-01	K	CYLINDER COVER COMPL.
506 37 83-02	C	WHEEL	506 39 86-01	D	HOSE COMPL.
506 37 84-01	J	CABLE	506 39 90-01	M	O-RING
506 37 85-01	J	CABLE	506 39 91-01	M	PLUG
506 37 95-01	F	SPRING	506 40 99-01	M	GASKET & DIAPHRAGM KIT
506 37 96-20	B	BUSHING	506 41 00-01	M	REPAIR KIT
506 37 96-25	B	BUSHING	506 41 23-01	D	GASKET
506 38 15-01	F	HEAT SHIELD	537 01 25-01	M	BALL
506 38 26-01	P	TOOL	537 01 26-01	M	SPRING
506 38 53-02	C	SET OF GASKETS	537 09 61-01	D	SLEEVE
506 38 55-01	L	BRACKET	537 13 70-01	D	NIPPLE
506 38 56-11	H	STARTER DEVICE COMPL.	537 17 62-01	M	VALVE
506 38 57-01	H	DECAL	537 17 70-01	M	THROTTLE LAP
506 38 58-01	G	HANDLE	537 17 78-01	M	PLUG
506 38 59-02	GN	VALVE CPL	537 18 00-01	D	PLUG
506 38 60-11	N	VALVE CPL	537 20 33-01	E	CUP
506 38 61-71	D	CYLINDER & PISTON CPL	537 21 03-07	F	INSULATOR
506 38 62-01	K	COVER	537 21 03-08	G	VIBRATION ABSORBER
506 38 64-01	L	PIPE	537 22 29-01	D	SCREW
506 38 65-11	F	TANK UNIT CPL.	537 24 45-01	D	CLAMP
506 38 66-01	F	FILTER	537 30 65-01	D	VALVE
506 38 67-01	F	SUPPORT	537 32 09-01	D	CLAMP
506 38 71-01	G	STOP HANDLE	537 38 51-01	M	SCREW
506 38 75-01	L	FILTER	537 38 52-01	M	CLIP
506 38 78-34	J	CABLE	544 00 14-01	D	MUFFLER CPL
506 38 91-01	D	INSULATOR	544 00 31-01	N	WET CUTTING KIT
506 39 30-01	C	WASHER	544 00 78-01	C	BRACKET
506 39 32-01	L	BRACKET	544 06 12-01	CFG	SCREW
506 39 34-01	C	DECAL	544 08 21-01	M	SCREW
506 39 36-01	A	PROTECTOR	544 08 22-01	M	SCREW
506 39 37-01	K	DECAL	720 12 40-20	F	PIN
506 39 38-01	K	DECAL	725 53 29-55	AB	SCREW
506 39 41-02	J	IGNITION MODULE	725 53 31-55	B	SCREW
506 39 42-03	A	HOUSING	737 43 12-00	D	RETAINING
506 39 42-11	A	HOUSING	738 22 02-25	CE	BALL BEARING
506 39 46-01	F	COVER, TANK	740 43 13-00	H	O-RING
506 39 52-01	L	PLATE			

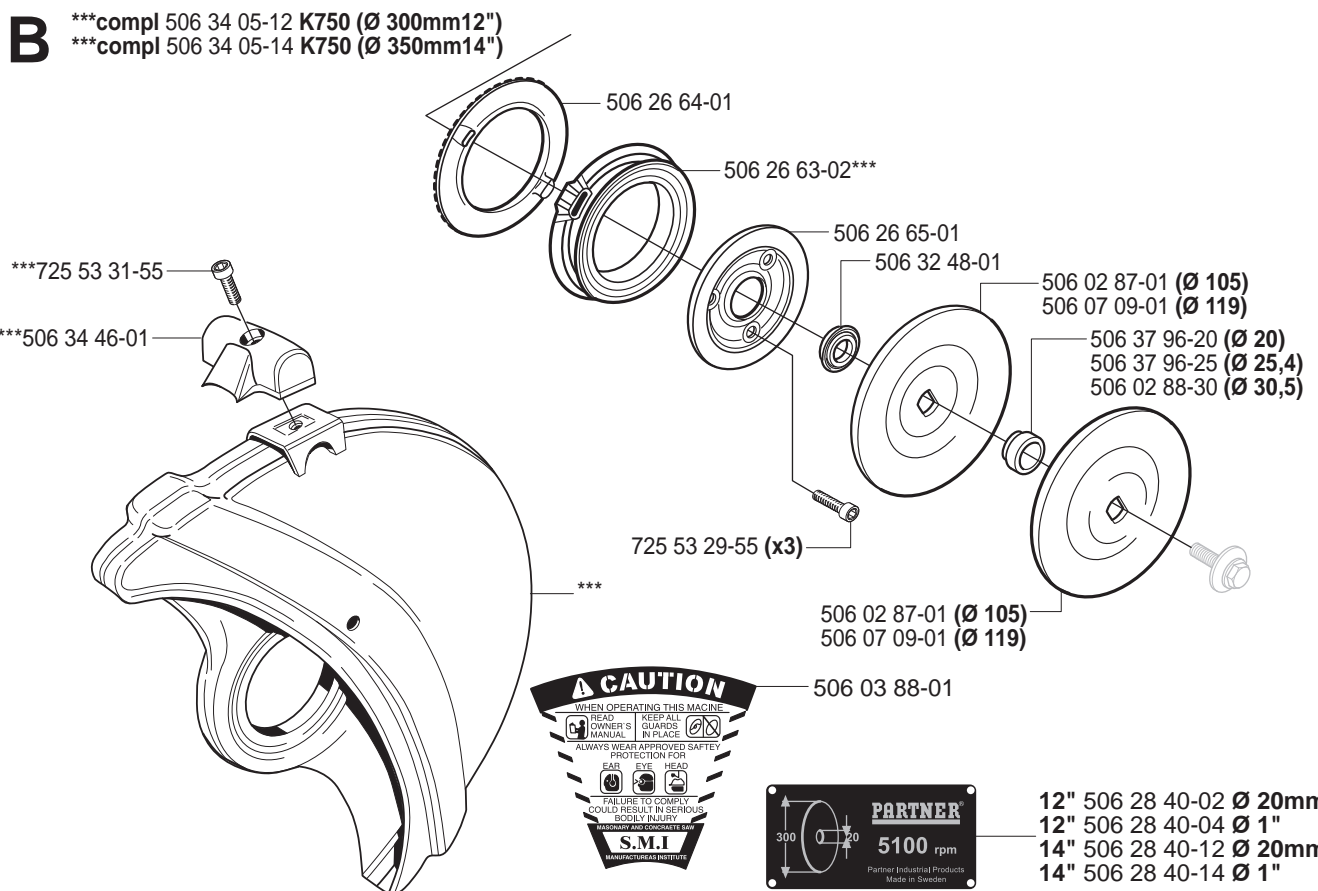
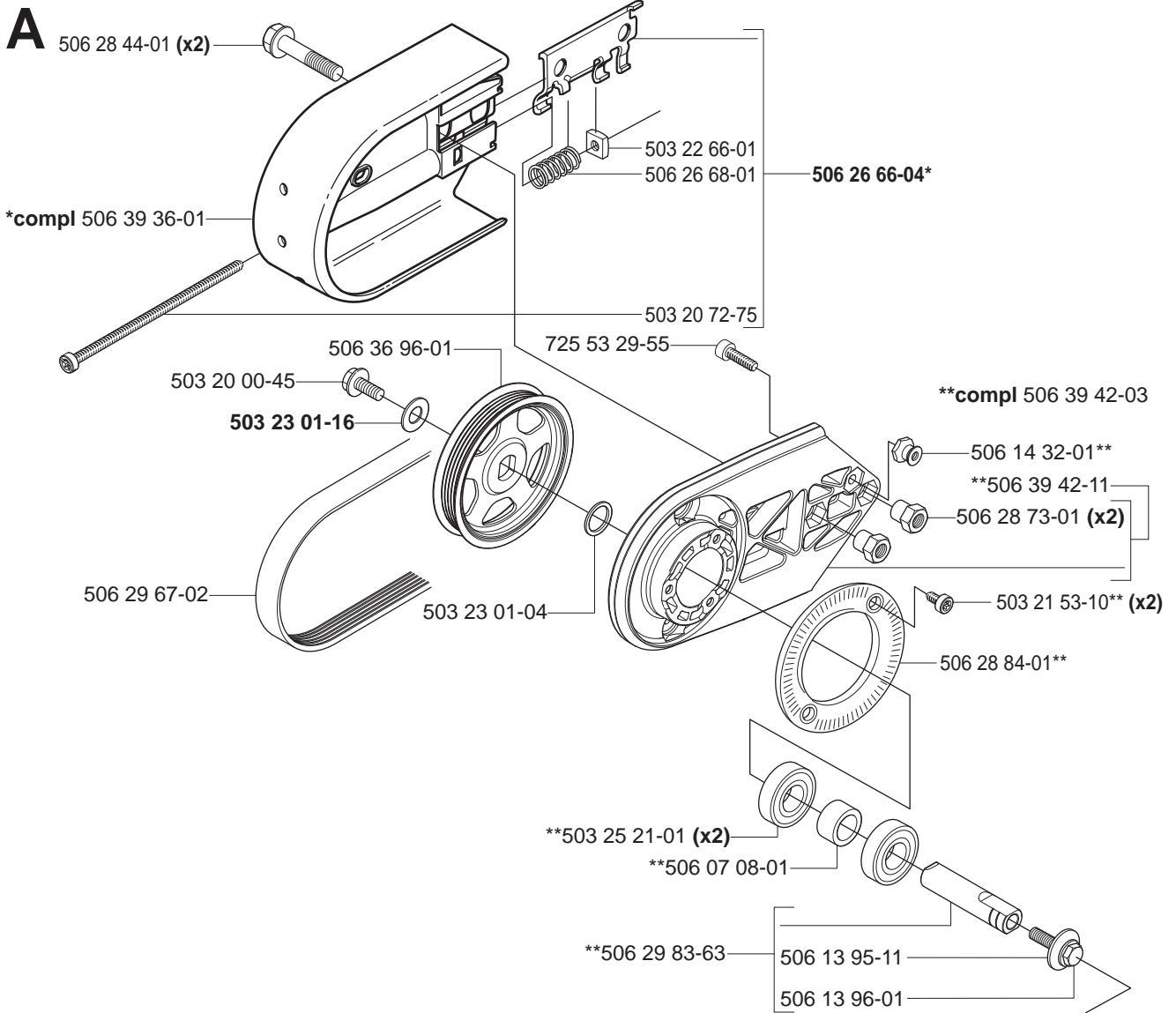

**C****(x2)** 503 21 53-21**PARTNER**

506 39 34-01

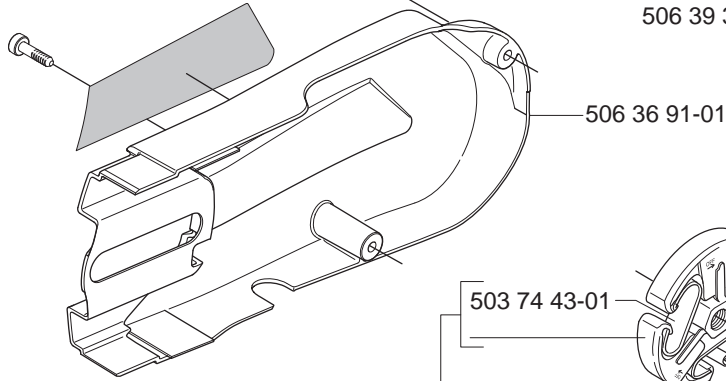

503 74 43-01

compl 506 37 83-02

compl 503 74 44-04

503 23 00-73

505 30 24-15

506 39 30-01

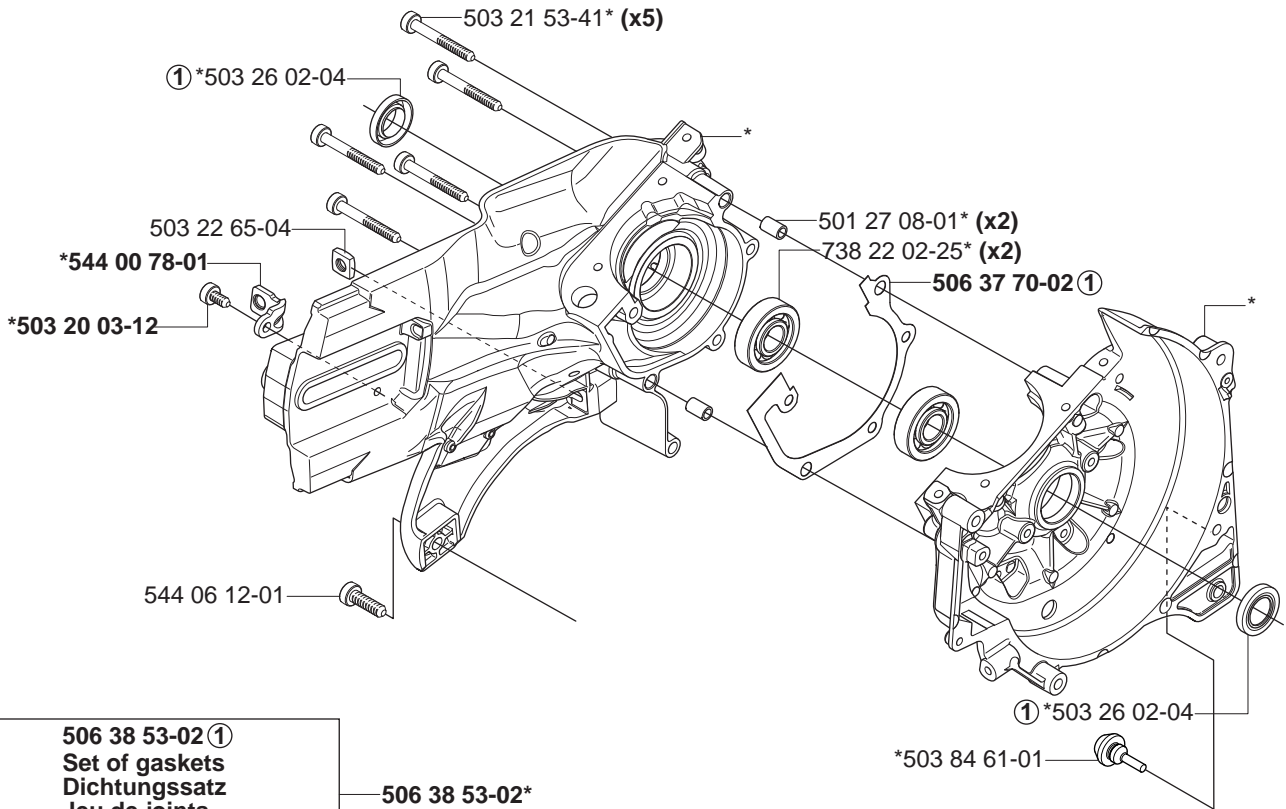
**Crankcase:****\*compl 506 37 57-02**

**506 38 53-02 ①**  
**Set of gaskets**  
**Dichtungssatz**  
**Jeu de joints**  
**Juego de juntas**  
**Packningssats**

506 38 53-02\*

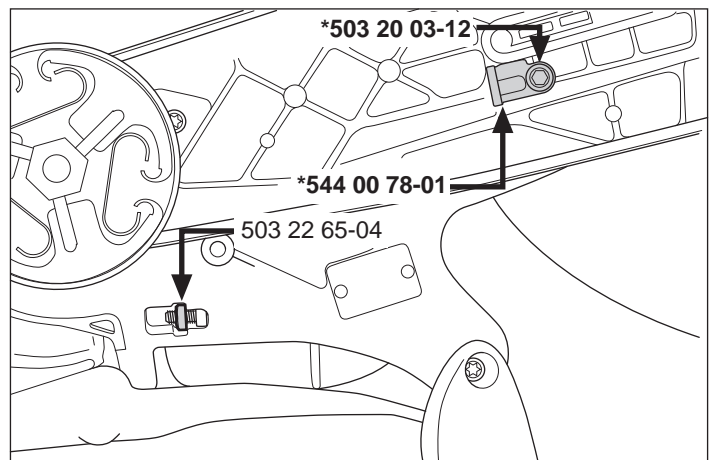
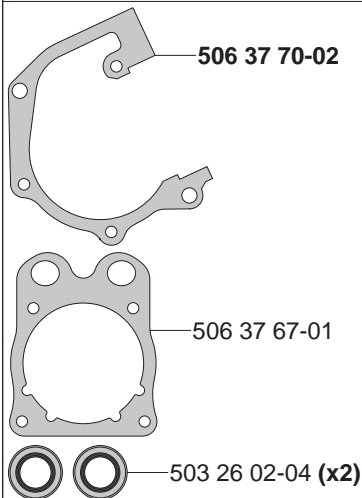

**D** Cylinder & Piston  
 \*compl 506 38 61-71

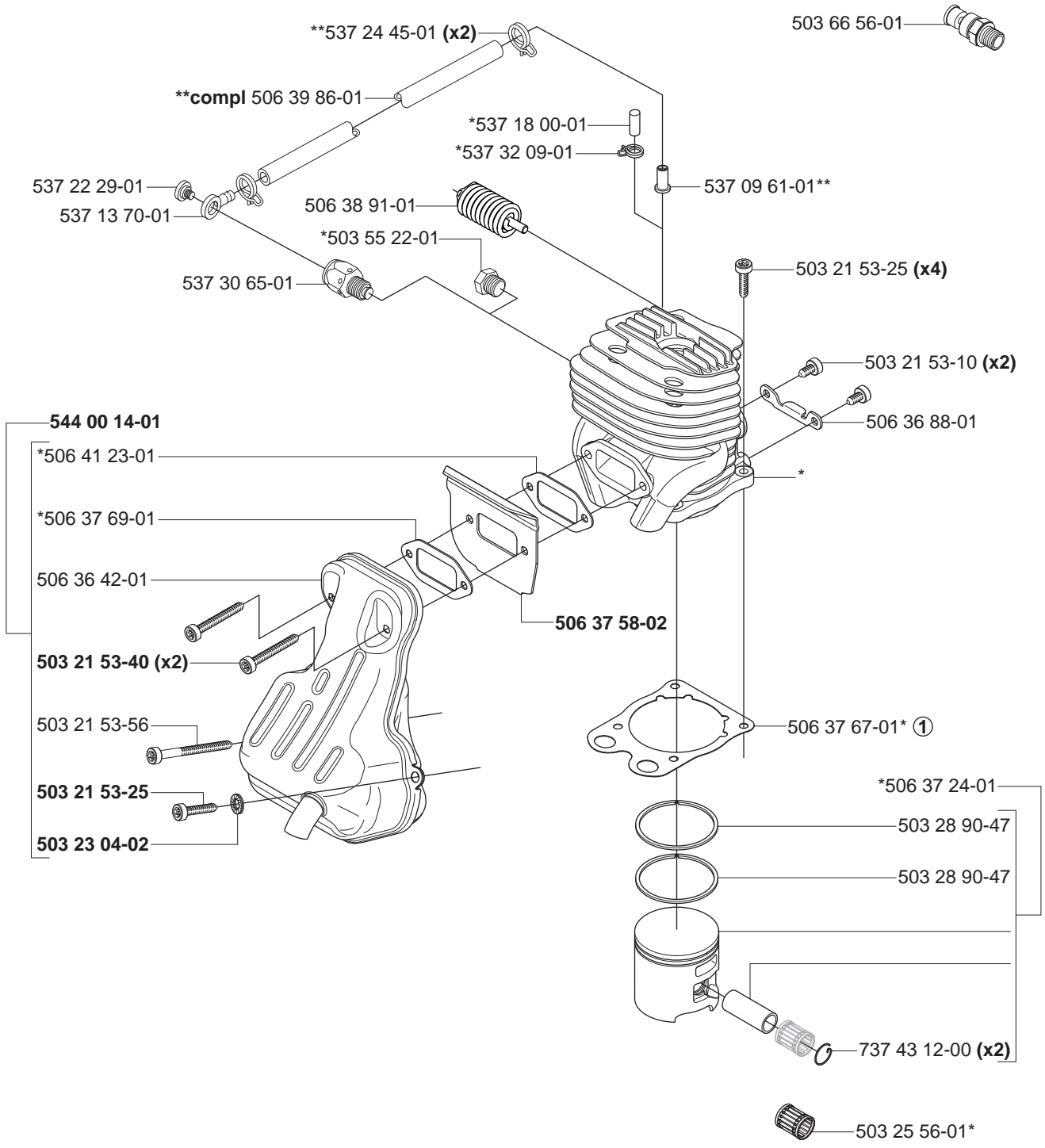

**E** Crankshaft  
 \*compl 506 37 10-71

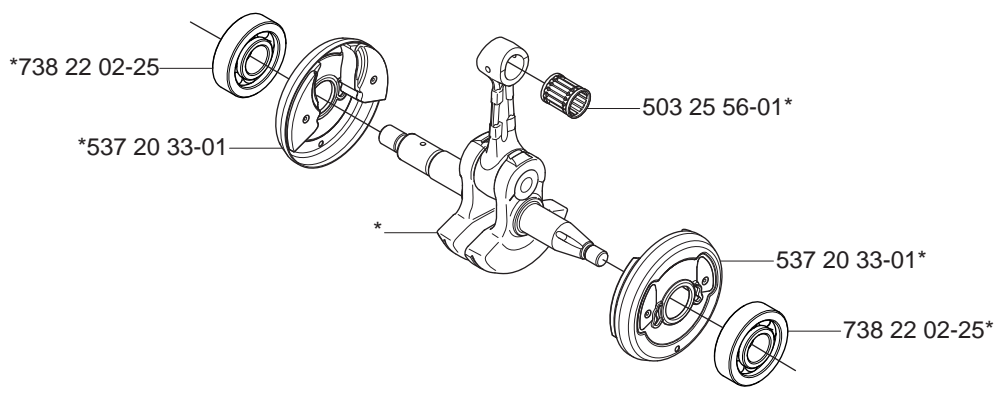

**F** Tank unit  
 \*compl 506 38 65-11

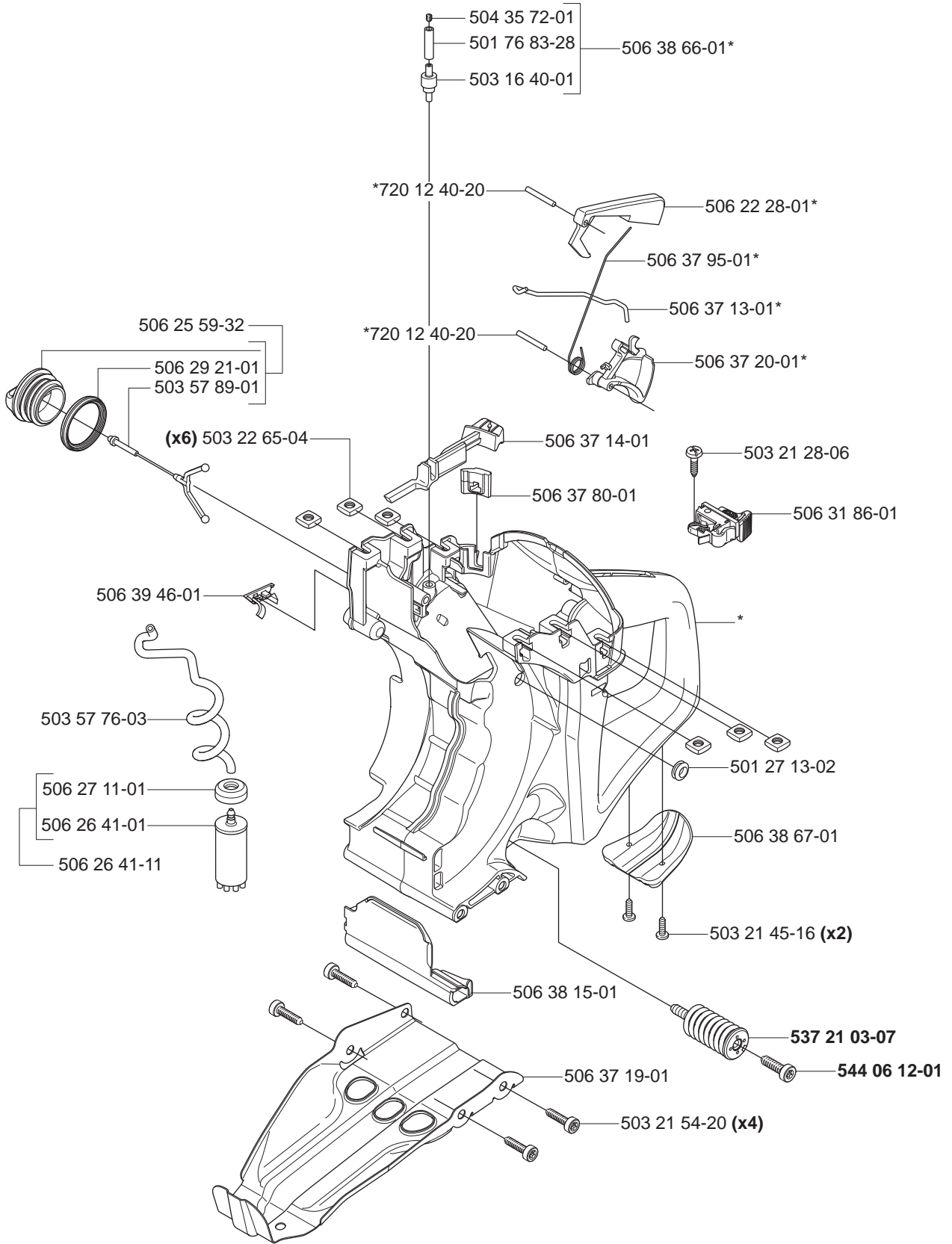

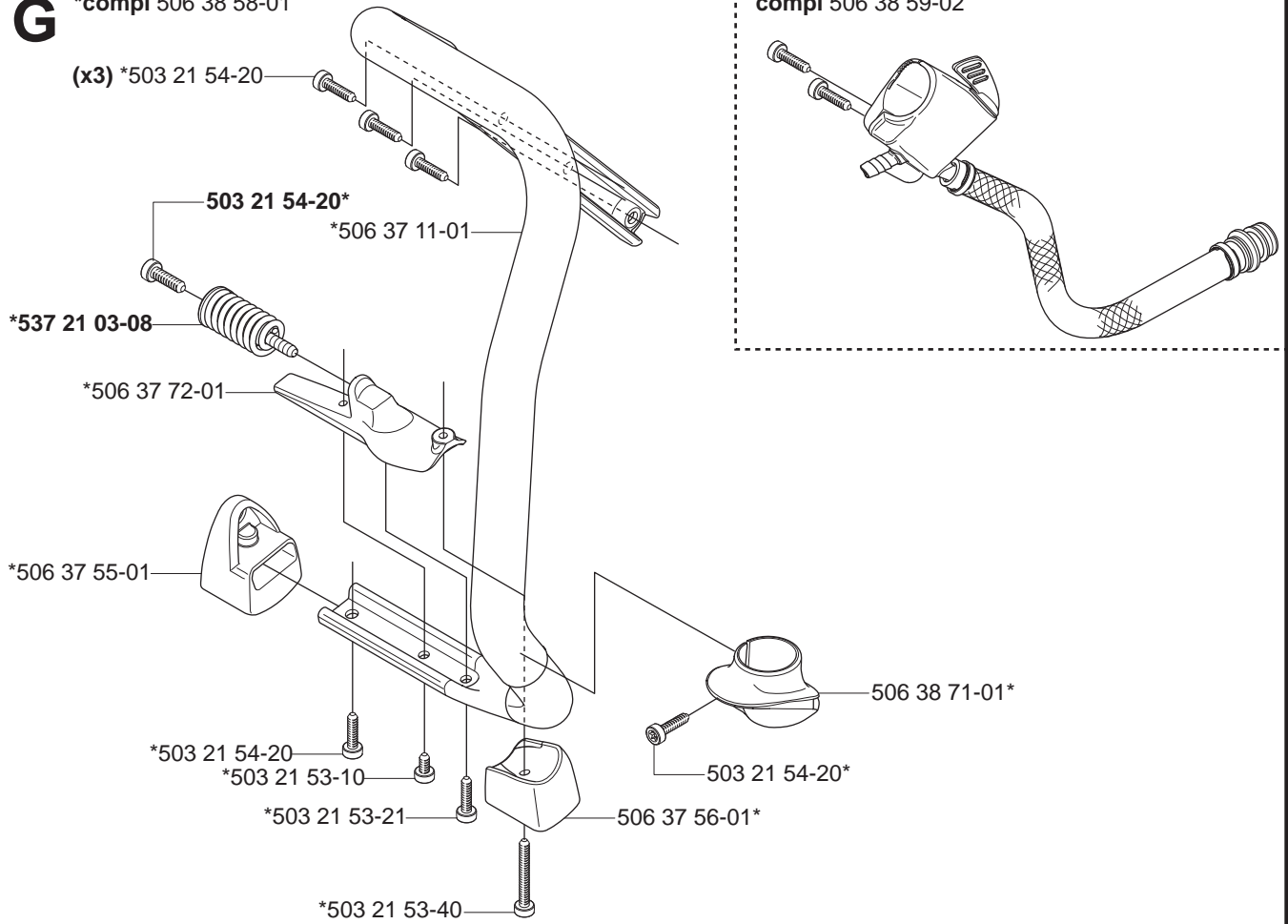
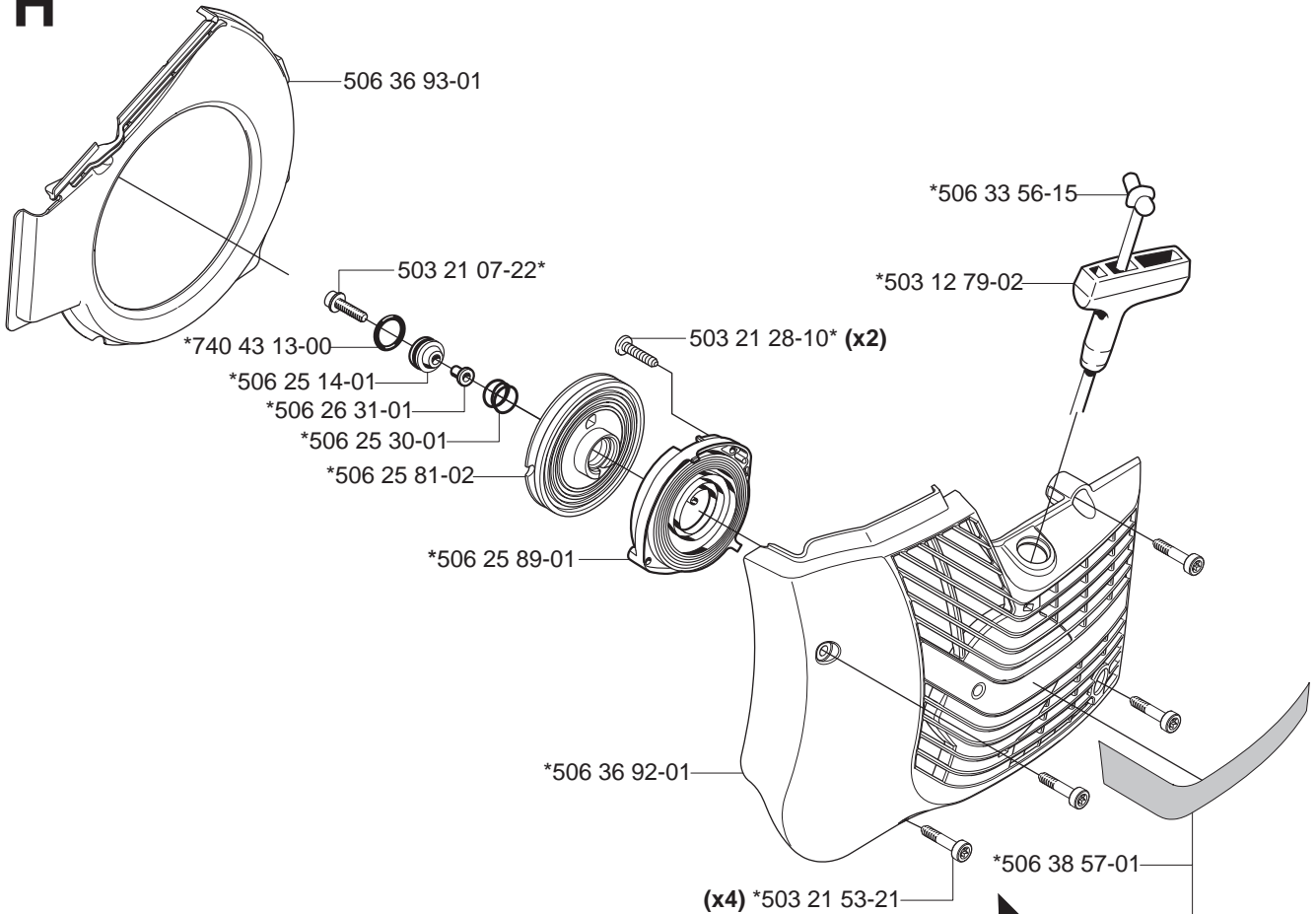
**G****\*compl 506 38 58-01****compl 506 38 59-02****H****\*compl 506 38 56-11**

DUAL CHARGE

**PARTNER**

**J**

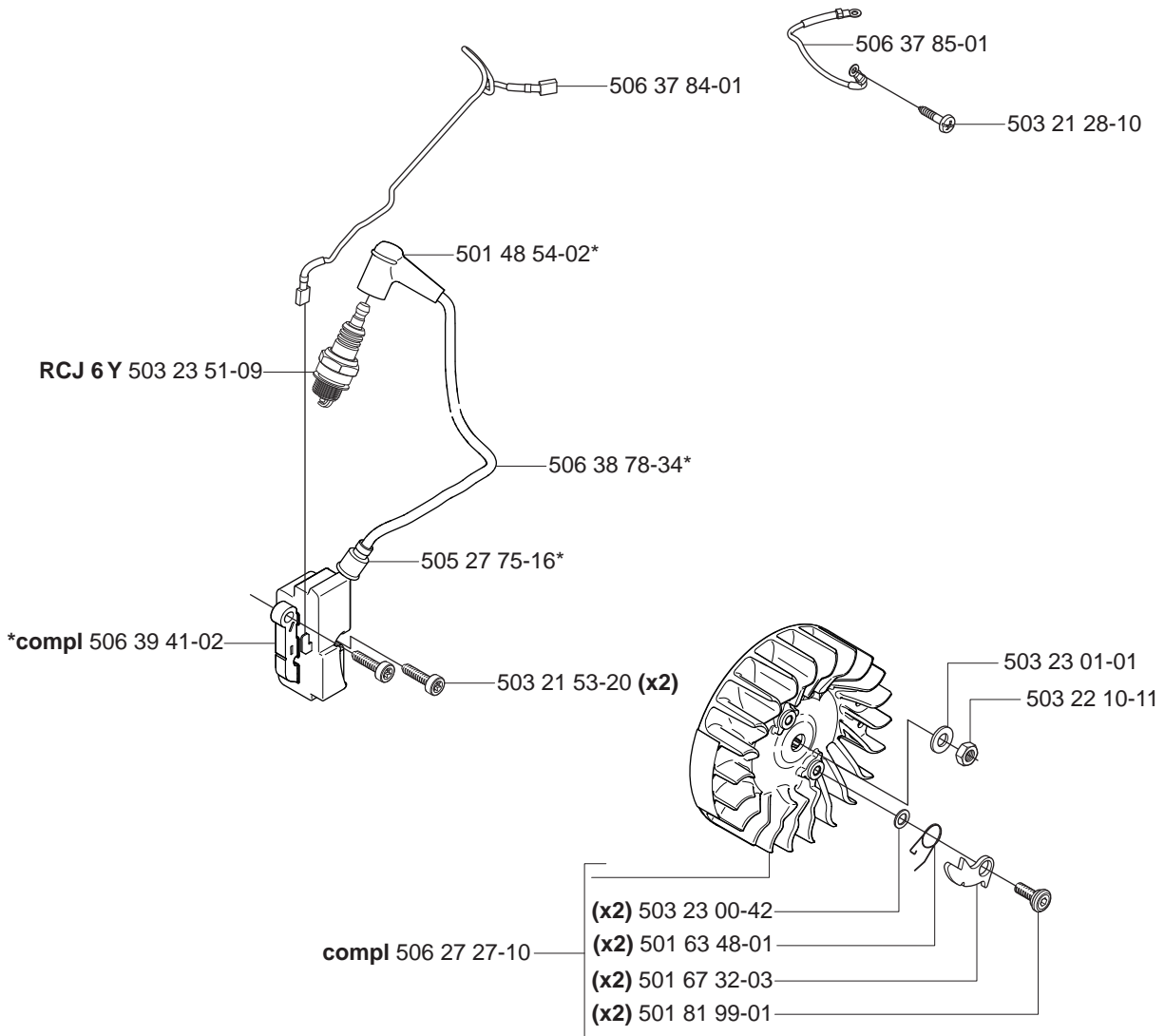

# K

(x2) 503 21 53-56

503 21 53-21

506 36 68-01

506 36 71-01

506 36 69-01

(x4) 503 21 53-21

\*compl 506 39 84-01

(x3) 503 21 53-21

506 27 84-32  
CE

506 27 84-51  
EPA USA

506 27 84-53  
EPA Canada



506 39 37-01\*

506 39 38-01\*

**K750**

506 38 62-01

506 37 04-01

506 37 03-01

L

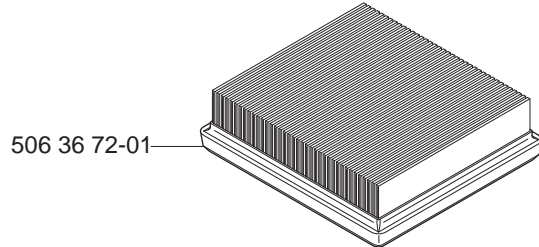

506 36 72-01

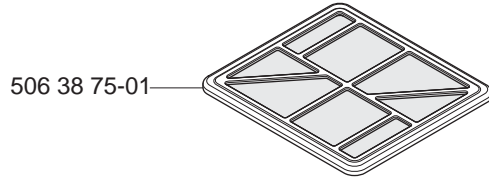

506 38 75-01

**\*compl 506 38 55-01**

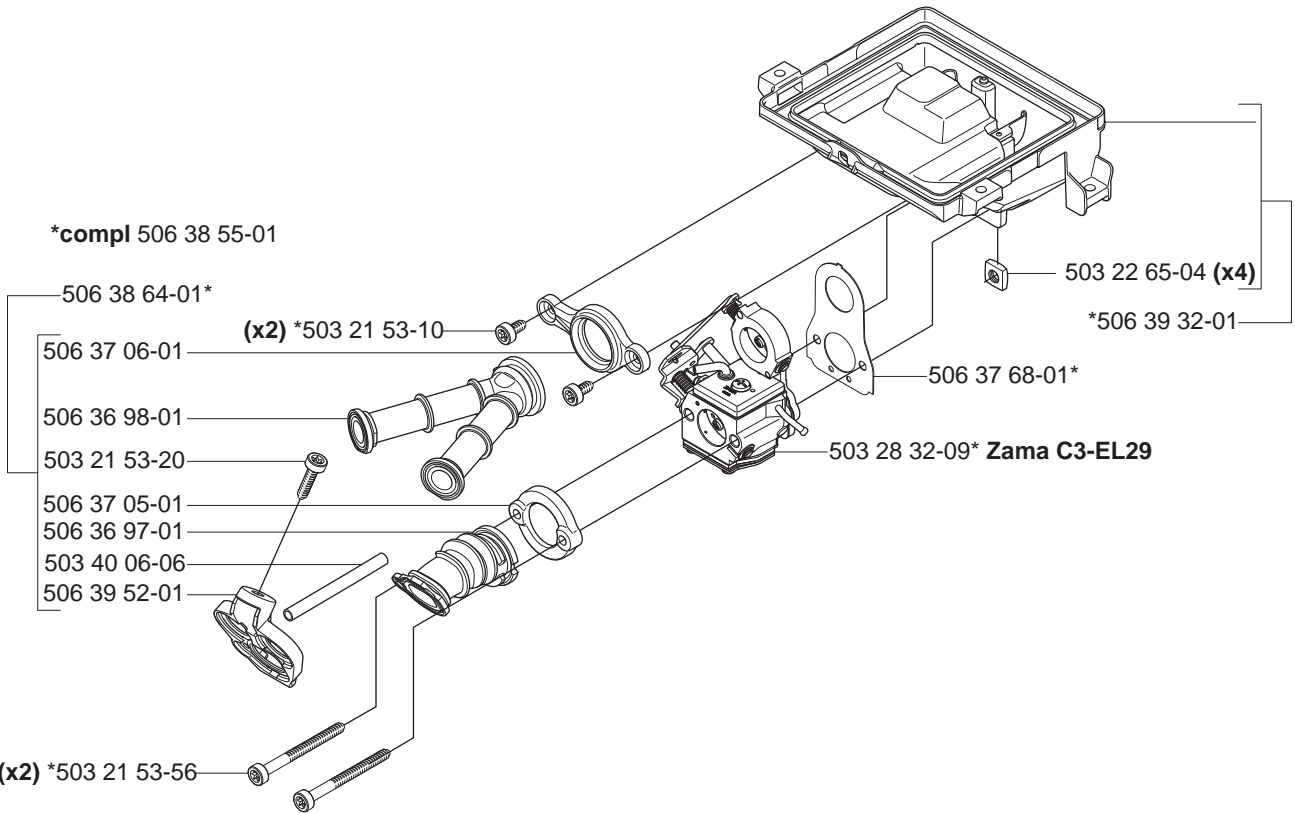

506 38 64-01\*

(x2) \*503 21 53-10

506 37 06-01

506 36 98-01

503 21 53-20

506 37 05-01

506 36 97-01

503 40 06-06

506 39 52-01

503 22 65-04 (x4)

\*506 39 32-01

506 37 68-01\*

503 28 32-09\* **Zama C3-EL29**

(x2) \*503 21 53-56

**M**

\*compl 503 28 32-09 ZAMA C3-EL29

**ZAMA C3-EL29**

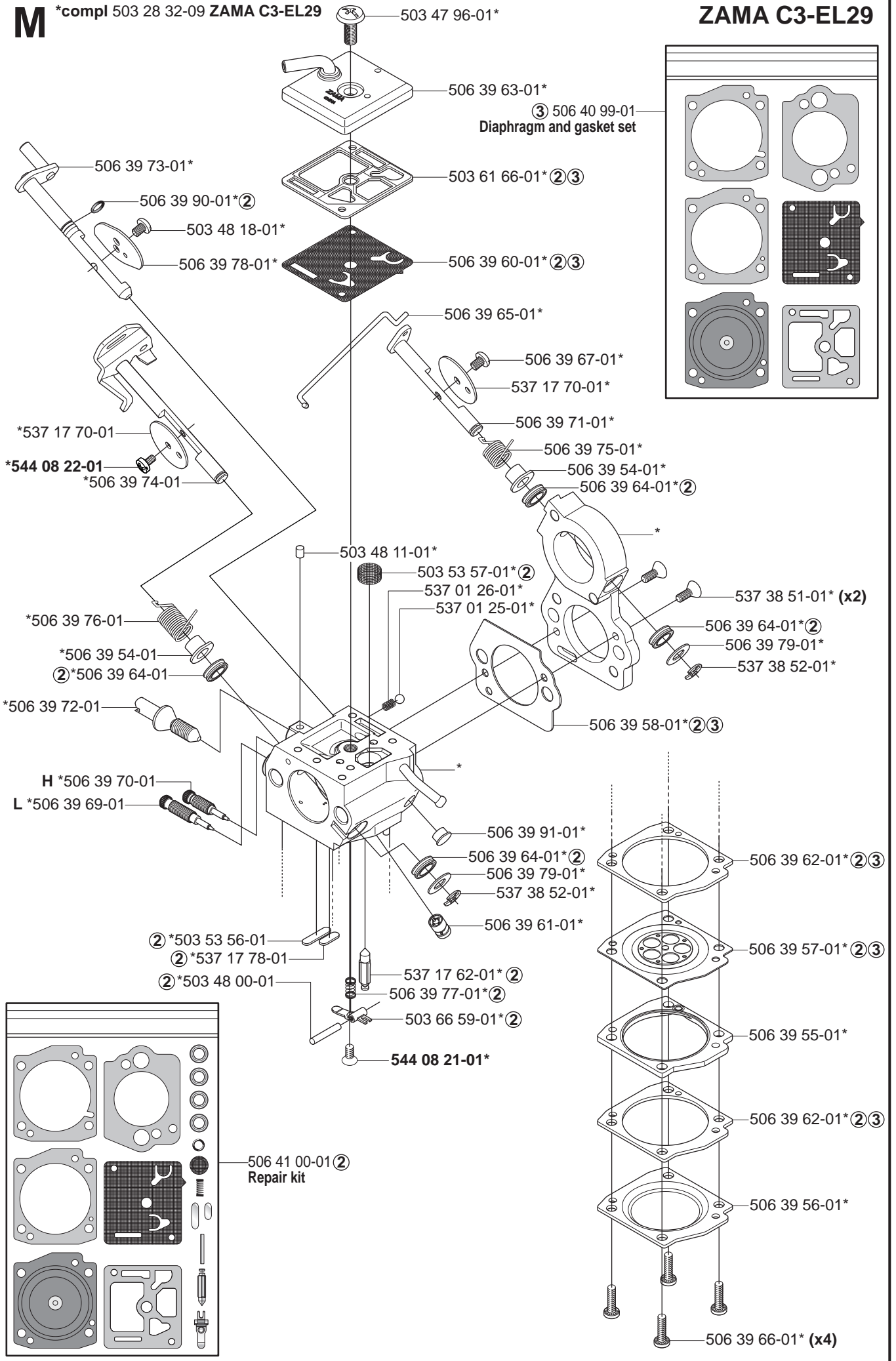

**N** Wet cutting kit  
\*compl 544 00 31-01

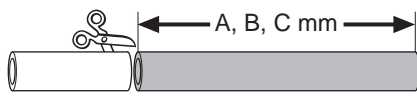
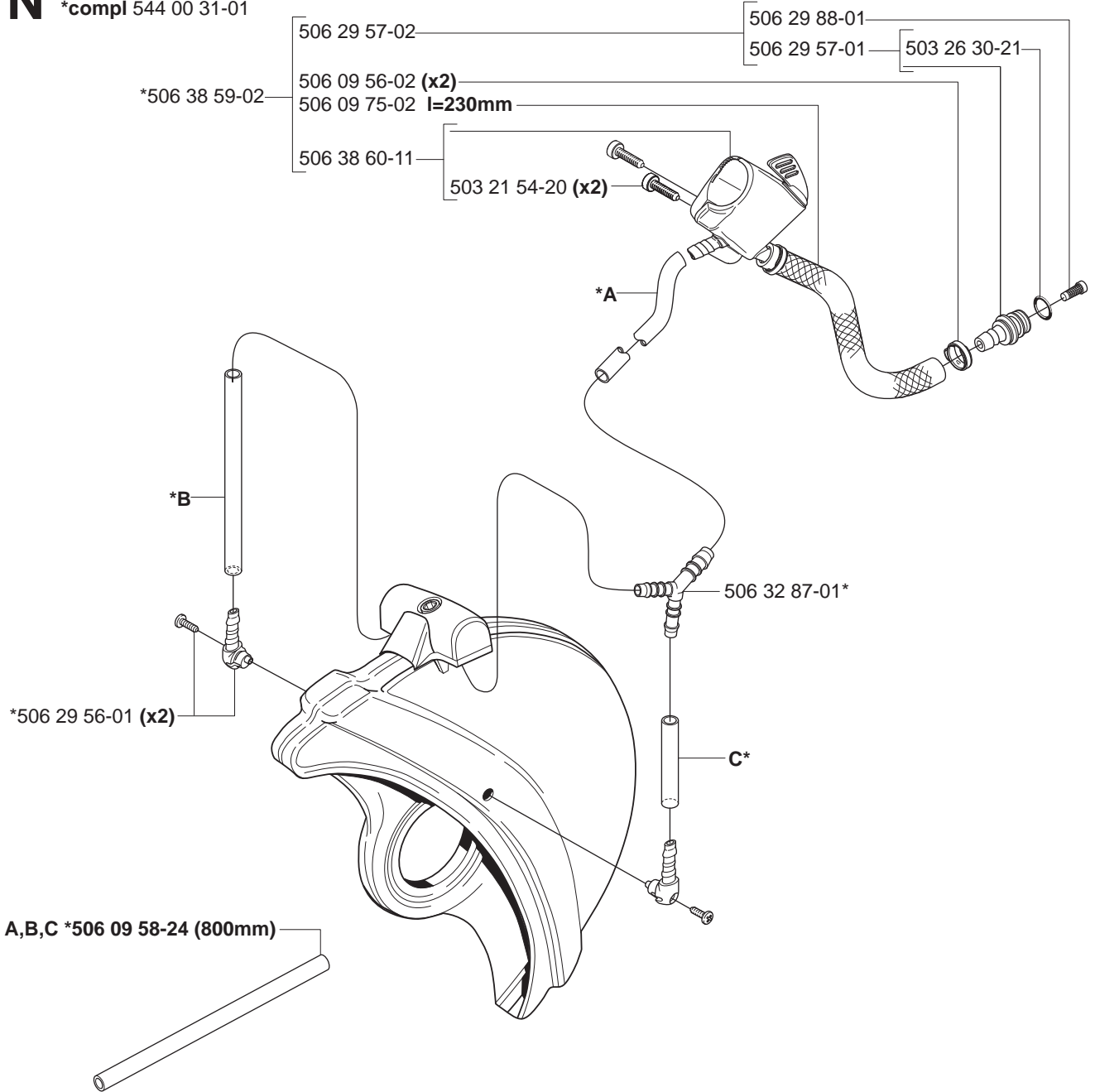

Product	A (mm)	B (mm)	C (mm)
K750 12"	240	240	45
K750 14"	240	280	45

**P** Accessories  
Zubehöre  
Accessoires  
Accesorios  
Tillbehör

